

# Inline Filters

## Reservoir Equipment

### Metal Inline Filter - Specification



**Construction:**  
Head – zinc.  
Bowl – Aluminium  
BS1470/1050A. 1987.

**Element:**  
Zintec/Stainless steel.  
125 micron\*.

**Max. flow:**  
90 l/min.

**Max working pressure:**  
7 bar.

**Thread:**  
G1.

**Working temperature:**  
-30°C to +80°C.

**Seal:**  
Nitrile.

**Bowl tightening torque:**  
12 Nm.

**Flow direction:**  
From outside to inside.

**Weight:**  
1.5 Kg.

\*Alternative media can be specified.

### Installation Details

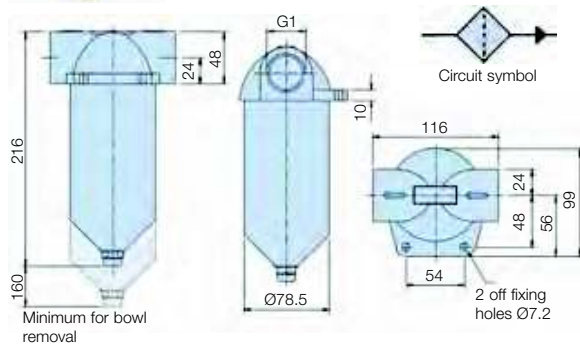

### Filter Selection

**Total assembly pressure drop flow curve**  
Oil Viscosity 30 cSt      Relative density 0.856

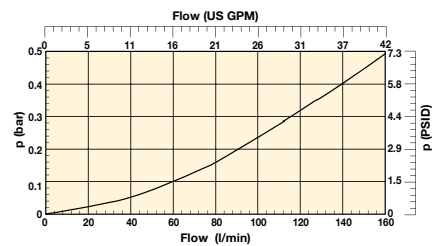

### Ordering Information

#### Standard products table

Part number	Flow l/min	Thread BSP	Micron rating	Replacement element	Supersedes
<b>IL1115</b>	90	G1	125	<b>EIL1115</b>	E.I.L.1115

Note 1: Part numbers featured with bold highlighted codes will ensure a 'standard' product selection.  
Note 2: Alternate displayed part number selection will require you to contact Parker Filtration for availability.

### Non-Corrosible Inline Filter - Specification



**Construction:**  
Housing and bowl moulded in polyester.

**Element:**  
Stainless steel mesh.  
125 micron\*.

**Max. flow:**  
120 l/min.

**Max working pressure:**  
7 bar.

**Thread:**  
G1.

\*For alternative media consult Parker Filtration  
Note: When using with water, protect from freezing.

**Working temperature:**  
-30°C to +80°C.  
(+60°C water).

**Seal:**  
Nitrile.

**Bowl tightening torque:**  
12 Nm.

**Bowl tightening note:**  
A box or ring spanner is recommended.

**Flow direction:**  
From outside to inside.

**Weight:**  
0.5 Kg.

### Installation Details

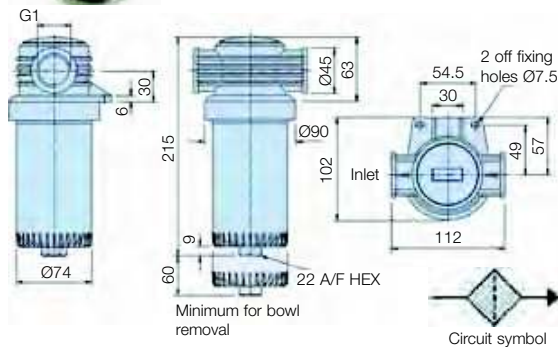

**Total assembly pressure drop flow curve**  
Oil Viscosity 30 cSt      Relative density 0.856

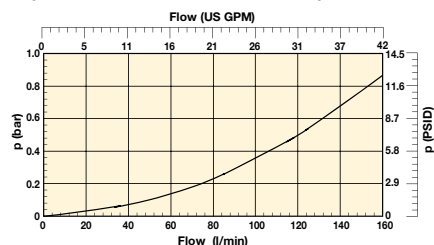

### Ordering Information

#### Standard products table

Part number	Supersedes	Thread BSP	Appliance	Micron rating	Weight	Replacement element
<b>IL761151</b>	IL.1151	1	Oil	125	0.5	<b>R.76115</b>
<b>IL761251</b>	IL.1251	1	Water	125	0.5	<b>R.76125</b>

Note 1: Part numbers featured with bold highlighted codes will ensure a 'standard' product selection.  
Note 2: Alternate displayed part number selection will require you to contact Parker Filtration for availability.



**Parker Hannifin**  
Hydraulic Filter Division Europe  
FDHB500UK.