

aerospace
climate control
electromechanical
filtration
fluid & gas handling
hydraulics
pneumatics
process control
sealing & shielding



Moduflow™ *Plus* Series

Low Pressure Filters



ENGINEERING YOUR SUCCESS.

Moduflow™ Plus Series

Applications

- Power Unit Fabrication
- Off-line Filter Loops
- Mobile Equipment

The Moduflow filter is widely considered the most versatile filter available on the market.

The patented end cap minimizes turbulence and pressure loss through the filter, improving system performance.

The newly designed closed bottom elements for the RFP and ILP models insures all contamination remains trapped within the element as the filter is serviced.

A wide variety of visual and electrical indicators allows you to know exactly when the element needs to be serviced. There is even a “no element” indicator that can sense when there is not an element installed in the filter.

From top to bottom, the Moduflow filter series provides the high level of filtration and long term dependability so vital to today’s hydraulic systems.



Parker’s new patented Moduflow element was designed with built-in diverter and bypass valve, to meet your application needs.

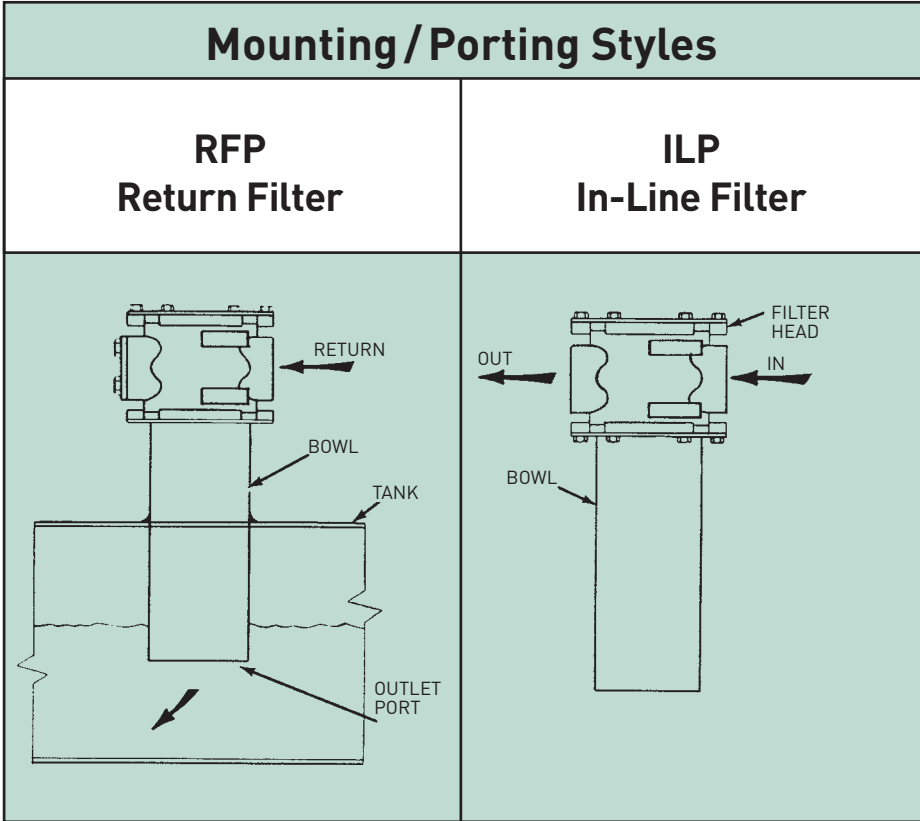

Moduflow™ Plus Series

Features

Flanges

- NPT or SAE 3/4" to 2"
- Lightweight aluminum

Cover

- Slotted for quick release
- Lightweight aluminum

Indicators

- Visual or electrical
- Mounted on either side
- Standard "no element" indication

Bowl

- Single or double length
- Durable steel construction

Bypass (not visible)

- Integral 35 psi bypass replaced with every element change

Element (not visible)

- Available in high performance Microglass III media
- Single or double length



Feature	Advantage	Benefit
<ul style="list-style-type: none"> • Top access element service 	<ul style="list-style-type: none"> • Oil remains in housing • Quicker elements change 	<ul style="list-style-type: none"> • No Spills • Reduced maintenance costs
<ul style="list-style-type: none"> • Slotted cover 	<ul style="list-style-type: none"> • Quick release cover • Cap screws remain in housing 	<ul style="list-style-type: none"> • Reduced maintenance costs • No loose parts to lose
<ul style="list-style-type: none"> • Closed bottom elements 	<ul style="list-style-type: none"> • Removes all contaminant during element service 	<ul style="list-style-type: none"> • No downtime contamination from servicing
<ul style="list-style-type: none"> • Visual or electrical indicators 	<ul style="list-style-type: none"> • Know exactly when to service elements 	<ul style="list-style-type: none"> • Helps prevent bypass condition • No premature disposal
<ul style="list-style-type: none"> • Flange face ports 	<ul style="list-style-type: none"> • Flexible mounting (3/4" to 2") 	<ul style="list-style-type: none"> • Easy plumbing to your system

Moduflow™ Plus Series

RFP-1 and ILP-1 Element Performance

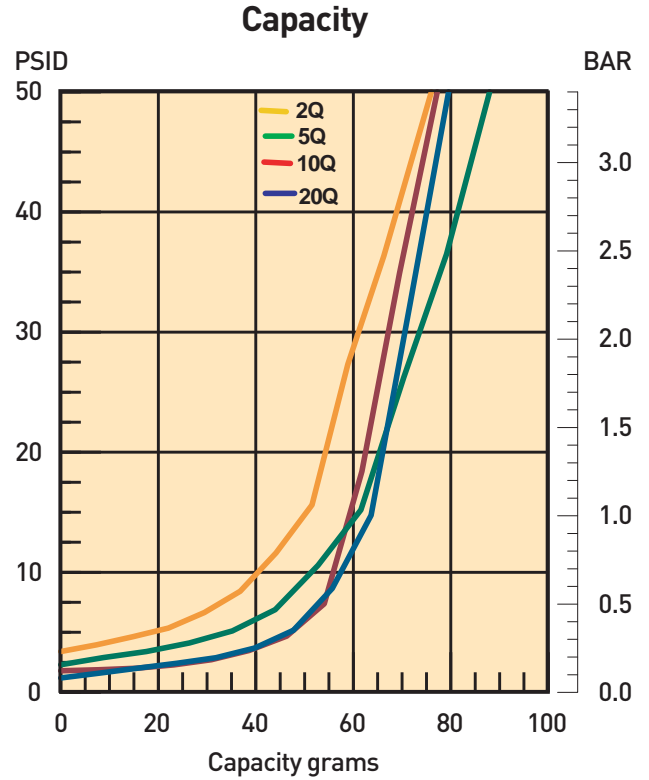
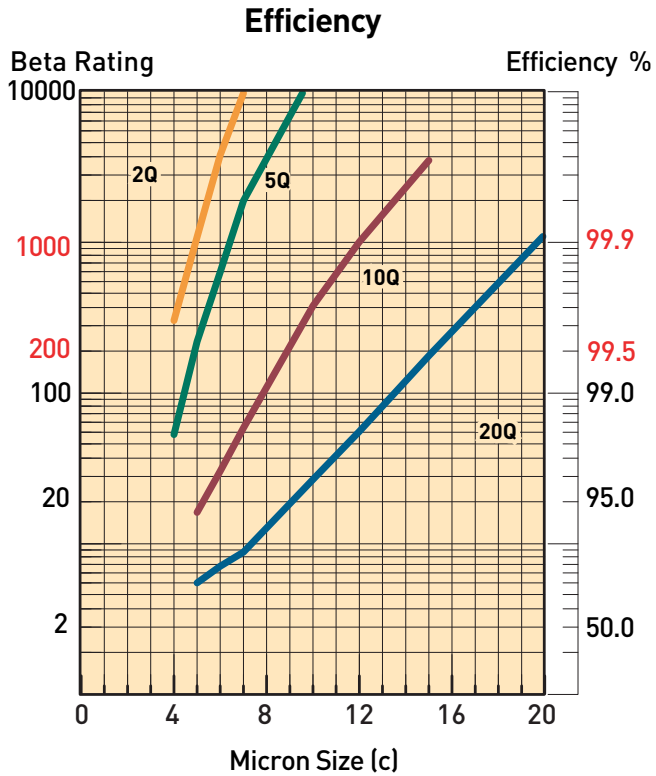

Multipass tests run @ 40 gpm to 50 psid terminal - 5mg/L BUGL

Flow vs. Pressure Loss

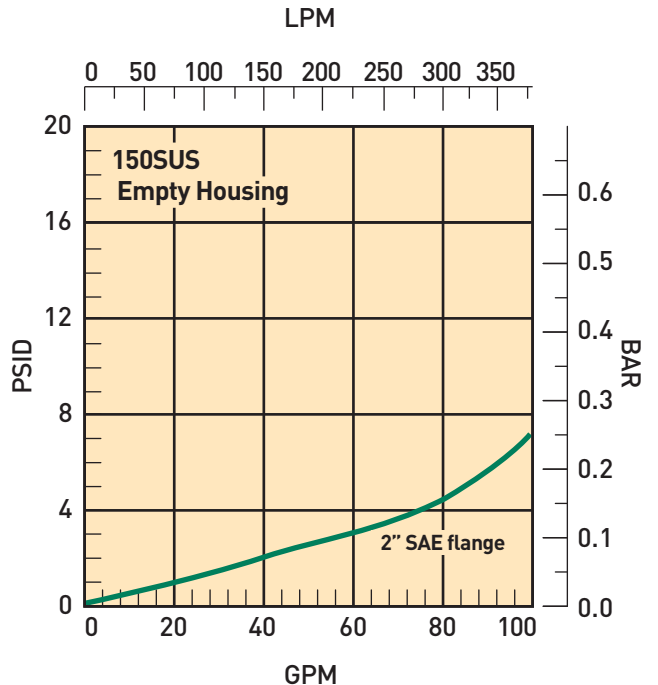
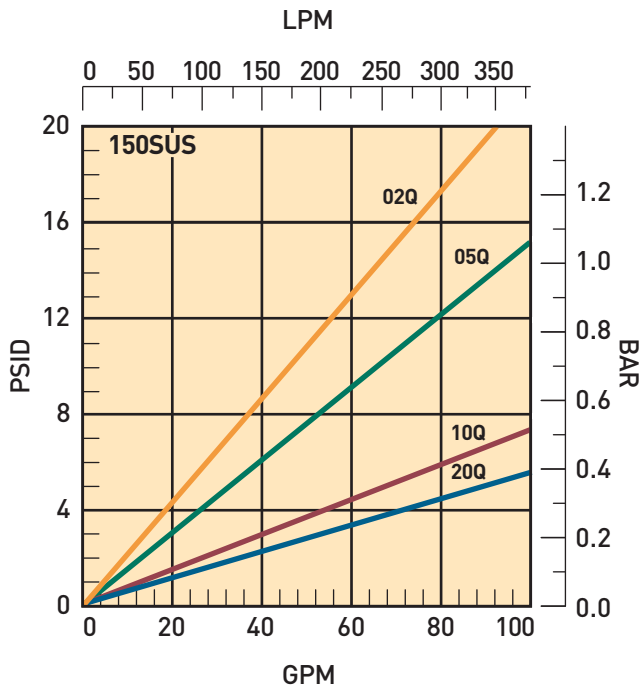

Moduflow™ Plus Series

RFP-2 and ILP-2 Element Performance

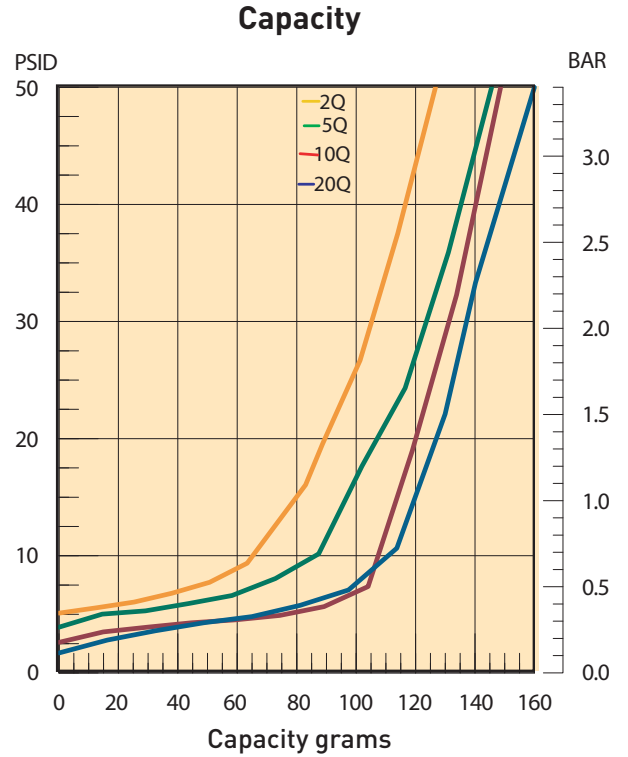
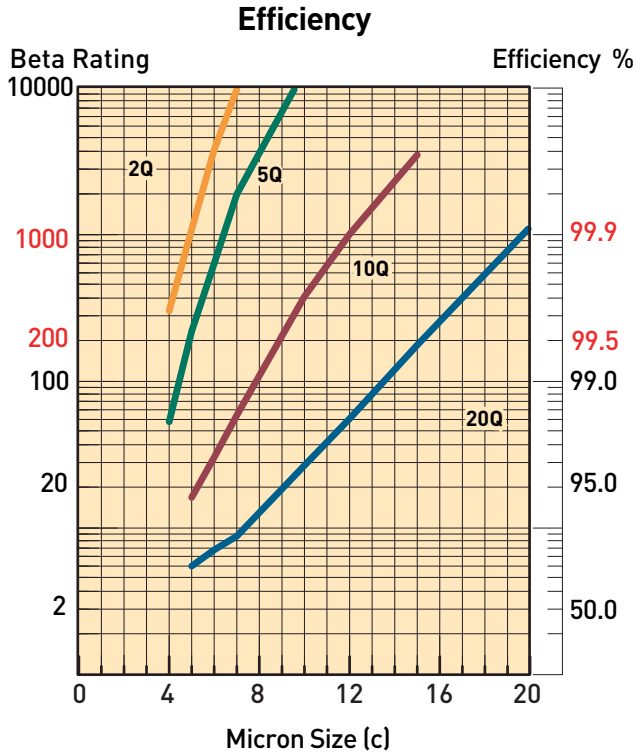

Multipass tests run @ 80 gpm to 50 psid terminal - 5mg/L BUGL

Flow vs. Pressure Loss

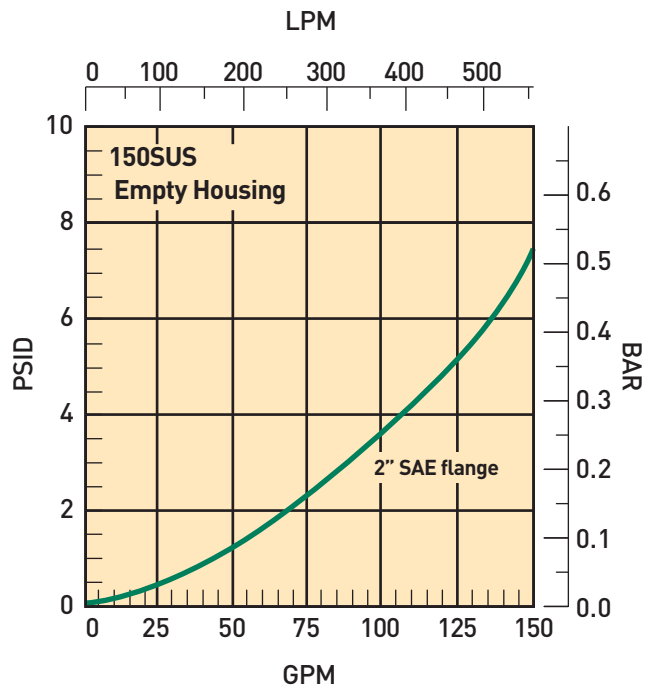
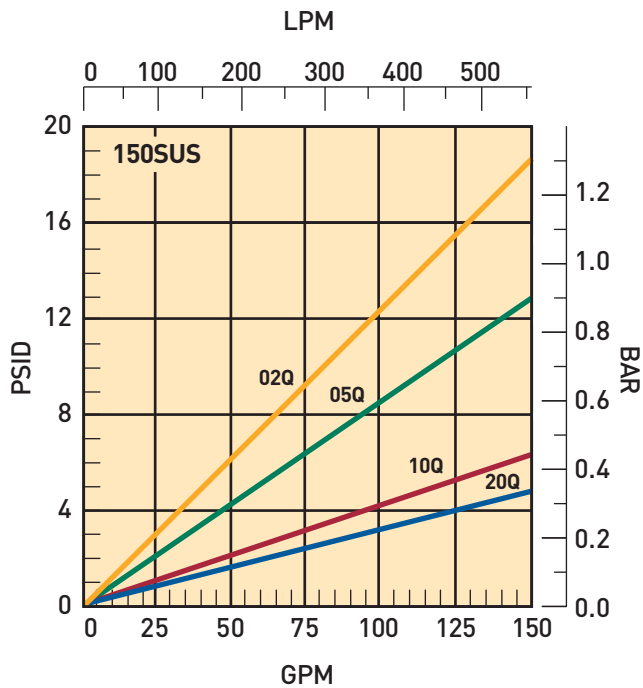

Moduflow™ Plus Series

Specifications: RFP, ILP

Pressure Ratings:

Maximum Allowable Operating Pressure (MAOP): 200 psi (13.8 bar)
 Design Safety Factor: 2:1
 Rated Fatigue Pressure: 150 psi (10.3 bar)

Element Burst Rating: 70 psid (4.8 bar)

Filter Materials:

Head, Cover, Flanges: die cast aluminum
 Bowl: steel

Operating Temperatures:

Nitrile: -40°F to 225°F (-40°C to 107°C)
 Fluorocarbon: -15°F to 275°F (-26°C to 135°C)

Weight (approximate):

Single: 20 lbs. (9.1 kg)
 Double: 25 lbs. (11.3 kg)

Indicators:

Visual (optional)
 Electrical (optional) 15A @ 250VAC / .5A @ 125 VDC
 Electrical ("D" option) 5A @ 250VAC / 3A @ 28 VDC

Color Coding:

White (normally closed)
 Red (normally open)
 Black (common)

Model	Dimensions: $\frac{\text{mm}}{\text{inch}}$			
	A	B	C	D
RFP-1 with optional 2" fitting	$\frac{68.3}{2.69}$	—	$\frac{390.0}{15.37}$	$\frac{117.1}{4.61}$
RFP-1 without optional 2" fitting	$\frac{65.0}{2.56}$	$\frac{378.0}{14.87}$	—	$\frac{114.0}{4.50}$
RFP-2 with optional 2" fitting	$\frac{68.3}{2.69}$	—	$\frac{625.0}{24.61}$	$\frac{117.1}{4.61}$
RFP-2 without optional 2" fitting	$\frac{68.3}{2.69}$	$\frac{612.0}{24.11}$	—	$\frac{114.0}{4.50}$
ILP-1	$\frac{65.0}{2.56}$	$\frac{336.0}{13.24}$	N/A	$\frac{117.1}{4.61}$
ILP-2	$\frac{68.3}{2.69}$	$\frac{618.0}{24.32}$	N/A	$\frac{117.1}{4.61}$

Drawings are for reference only.
 Contact factory for current version.

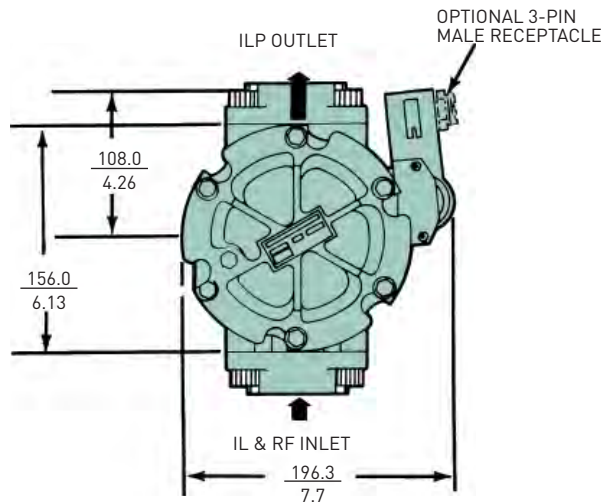

OPTIONAL PORT FLANGE

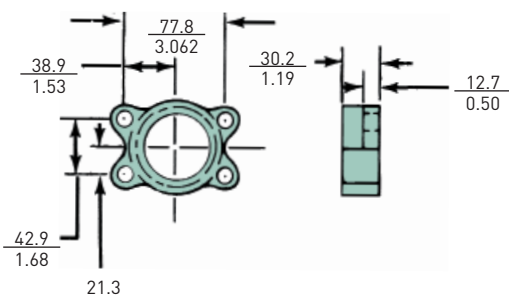

Linear Measure: $\frac{\text{millimeter}}{\text{inch}}$

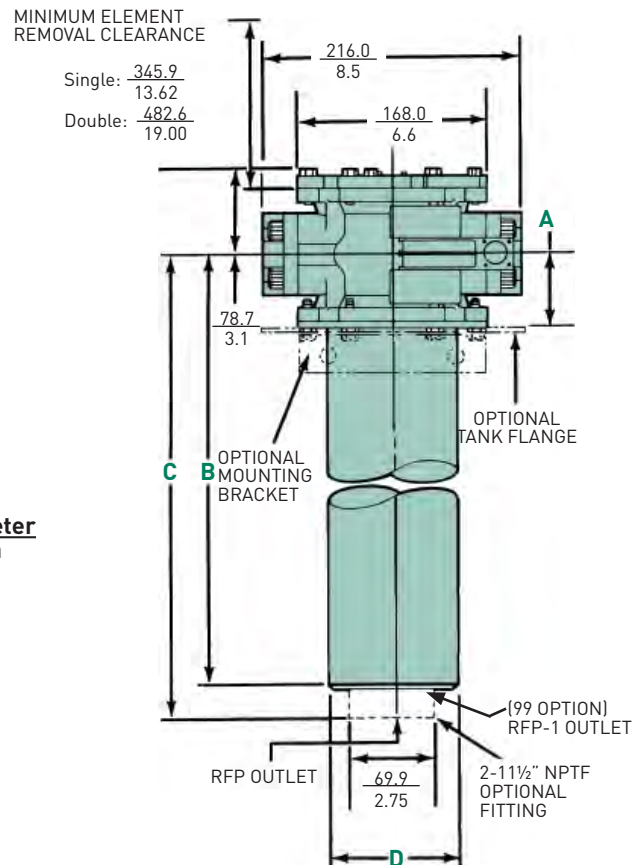

Moduflow™ Plus Series

Drawings are for reference only.
Contact factory for current version.

Specifications: DILP

Pressure Ratings:

Maximum Allowable Operating Pressure (MAOP): 200 psi (13.8 bar)
Design Safety Factor: 2:1
Rated Fatigue Pressure: 150 psi (10.3 bar)

Element Burst Rating: 70 psid (4.8 bar)

Filter Materials:

Divter Valve Assembly: die cast aluminum
Check Valve Assembly: die cast aluminum
Filter Assembly: see IL2 specifications

Operating Temperatures:

Nitrile: -40°F to 225°F (-40°C to 107°C)
Fluorocarbon: -15°F to 275°F (-26°C to 135°C)

Weight (approximate):

Single: 55 lbs. (24.9 kg) / Double: 65 lbs. (29.5 kg)

Indicators:

Visual (optional)
Electrical (optional) 15A @ 250VAC / .5A @ 125 VDC
Electrical ("D" option) 5A @ 250VAC / 3A @ 28 VDC

Color Coding:

White (normally closed)
Red (normally open)
Black (common)

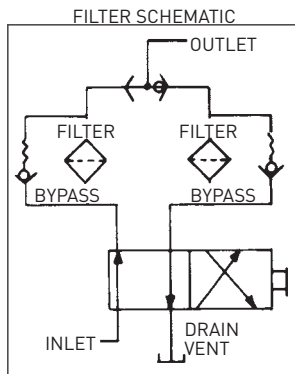

BOTH CHECK VALVES MOVE SAME DIRECTION

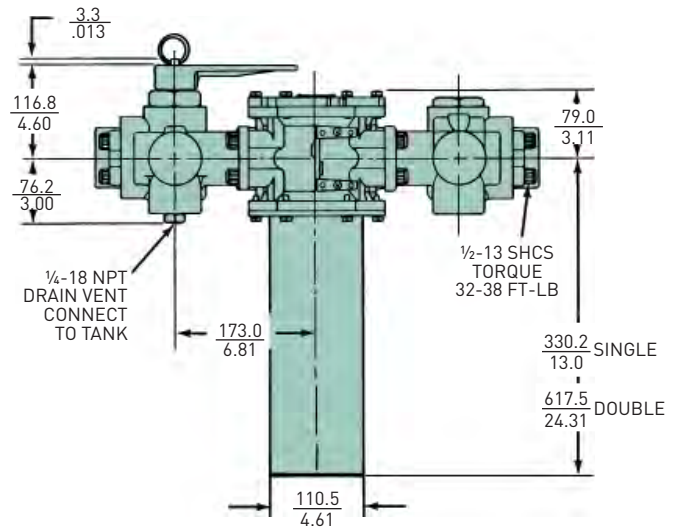

Linear Measure: millimeter / inch

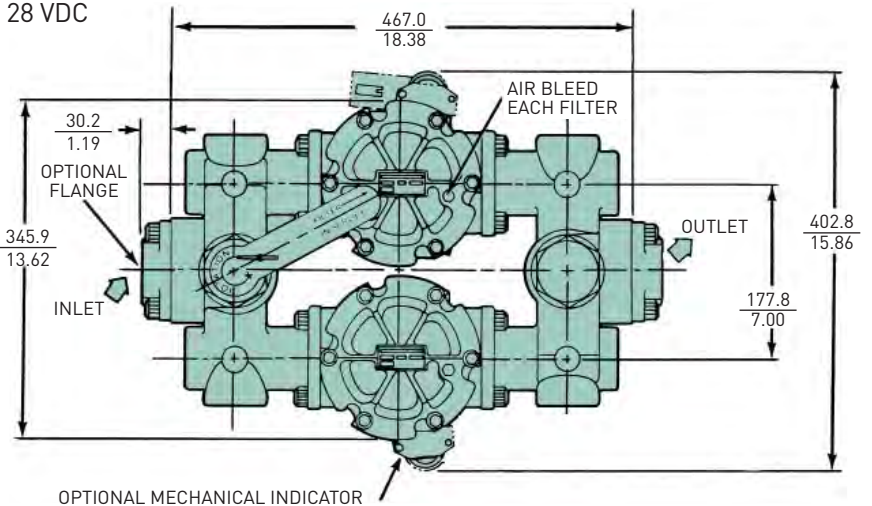

OPTIONAL MECHANICAL INDICATOR

Approximate handle torque required for changeover.

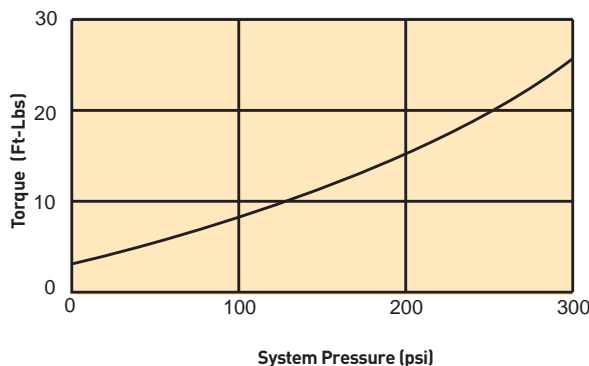

Typical Flow/Pressure Curves For Duplex Valves

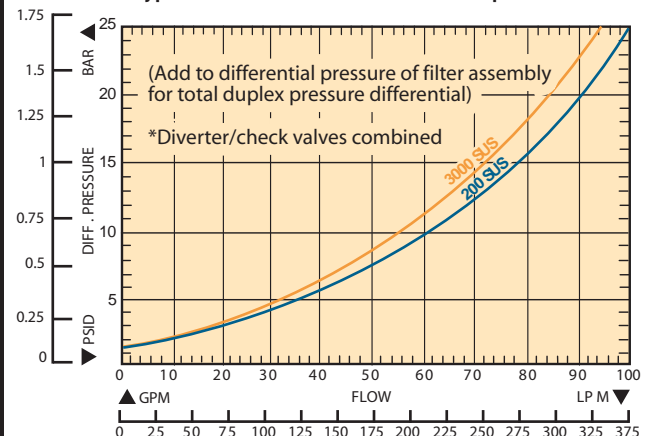

Moduflow™ Plus Series

Specifications

For return line applications (RFP), the fluid returning to the reservoir holds the check valve open. When the system is shut down, the check valve closes automatically.

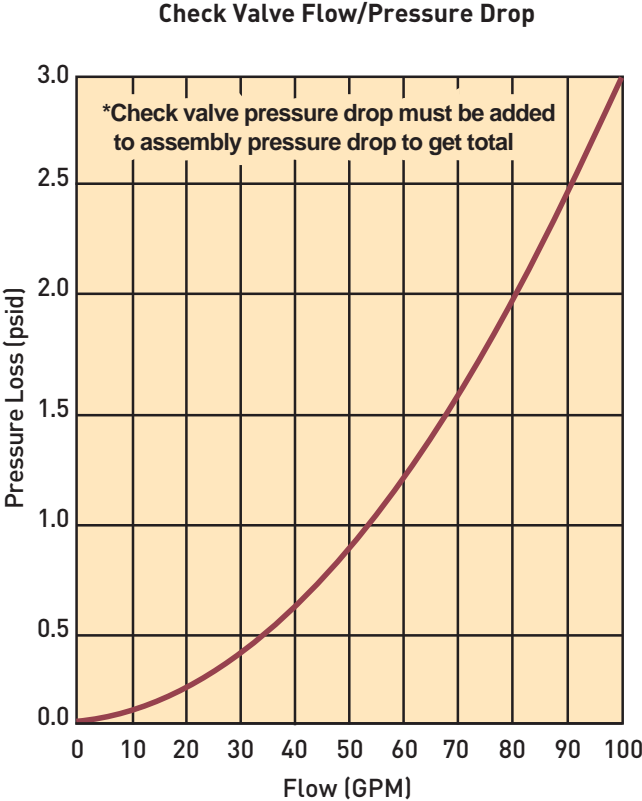

Linear Measure: millimeter
inch

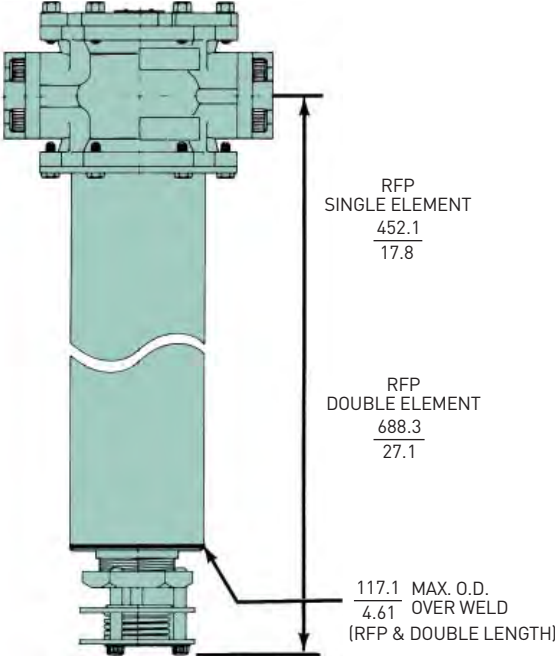

Drawings are for reference only.
Contact factory for current version.

Moduflow™ Plus Series

Specifications

Lower Cost than many single unit filters.

Moduflow™ Manifold Extended Filter Range

Use Model MM Manifold to handle return line flows up to 130 gpm.

- Rated static pressure: 300 psi
- Typical burst pressure: 900 psi
- Easily mounted on ModuFlow™

High Flows At Low Cost

The model MM manifold is designed to extend the flow range of ModuFlow™ Filters when operating with 10 Micron and finer filter media. When mounted to a pair of RFP-2 or ILP-2 filters, this manifold will allow flows up to 130 gpm in return lines (15 fps velocity).

Note: The Model MM manifold is not applicable to suction lines due to its pressure drop characteristics.

When used with two ModuFlow™ filters, the total cost is often less than a single unit filter rated for 130 gpm flow. Tank-top mounted (Model RFP) filters will require only one manifold on the filter inlet ports. In-line mounted (Model ILPav) filters will require two manifolds, one on the inlet and one on the outlet ports.

Multiple Uses

Although designed for manifold ModuFlow™ filters, the Model MM can be used in a variety of applications which require:

- Splitting flow between components

Such applications are frequently encountered on mobile equipment, machine tools, and large lubricating systems. In such applications, use of a manifold can often reduce total piping and installation costs.

Proven Reliability

The rugged design of the Model MM manifold has been proven in demanding mobil equipment applications. At the factory, we have cycle tested the Model MM through the full range of rated flow and pressure to insure reliable service.

Parker Filter Division maintains the same high standards in delivery, quality, and service. Considering this, plus features, flexibility, price, and performance, the Model MM manifold is a valuable addition to your fluid power component list.

FLOW/PRESSURE CURVE

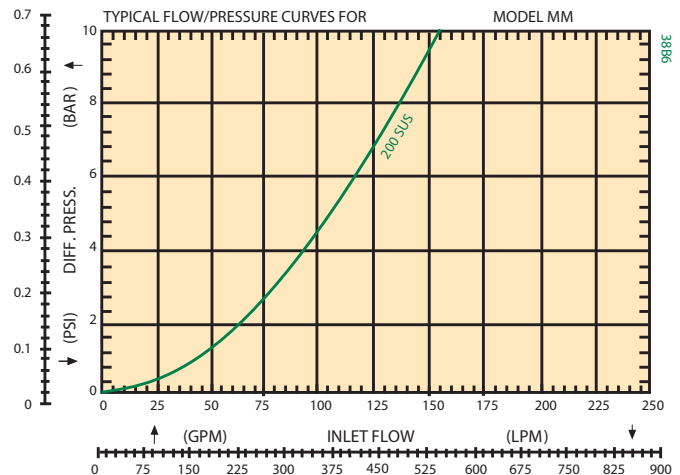

Moduflow™ Plus Series

Specifications

MANIFOLD SPECIFICATIONS

Rated Static Pressure, maximum:

20.7 bar (300 psi)

Typical Burst Pressure:

62.1 bar (900 psi)

Operating Temperature (Buna seals):

+121°C to -40°C (+250°F to 40°F)

Housing Material:

ANSI 356-T6 cast aluminum

Approximate Shipping Weight:

3.6 kg (8 lbs)

Porting: See Options Below

Order Screws and O-Rings Separately:

Inlet & outlet screws (12 required):

Order P/N 900228

Outlet port o-rings (2 required):

Nitrite: Order P/N N72228

Fluorocarbon: Order P/N V92228

HOW TO ORDER MANIFOLDS:

Part Number	Description
926466	Moduflow Manifold

- * Tank-top mounted RFP filters will require one manifold on filter inlets: in-line mounted ILP filters will require two manifolds on both inlets and outlets.

Drawings are for reference only.
Contact factory for current version.

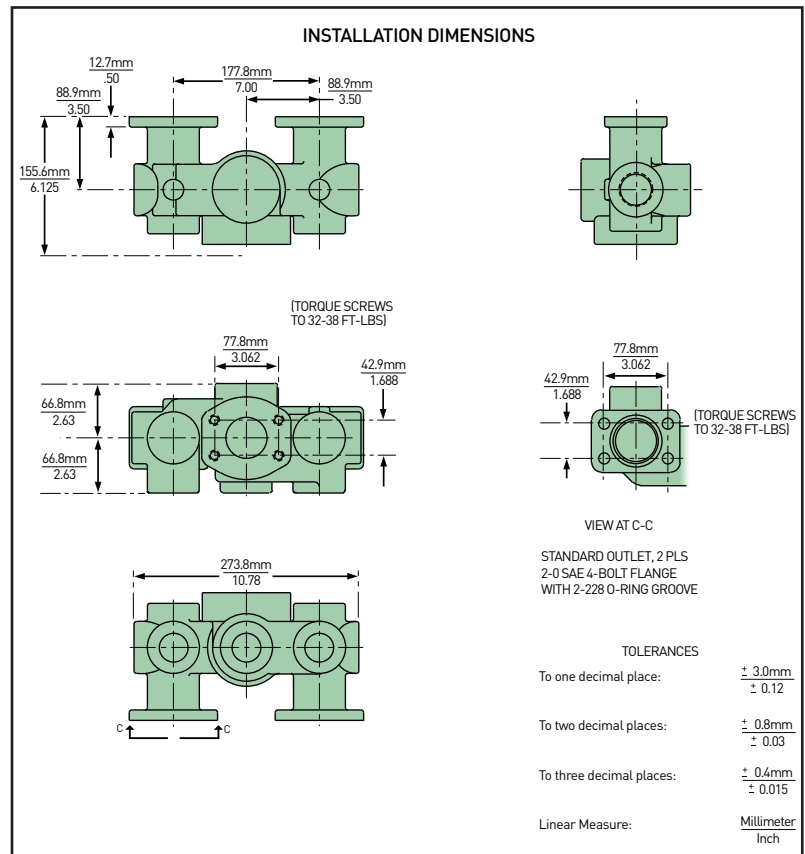

Moduflow™ Plus Series

Accessories

Linear Measure: millimeter
inch

OPTIONAL MOUNTING BRACKET (924904)

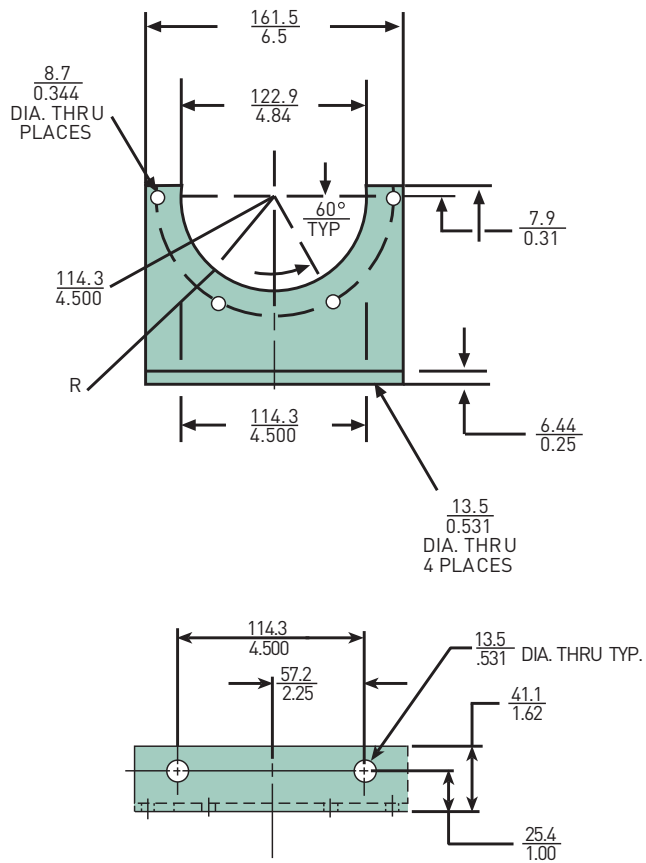

"M" OPTION-VISUAL INDICATOR,
NO ELEMENT WARNING



Drawings are for reference only.
Contact factory for current version.

"E" OPTION-ELECTRICAL INDICATOR

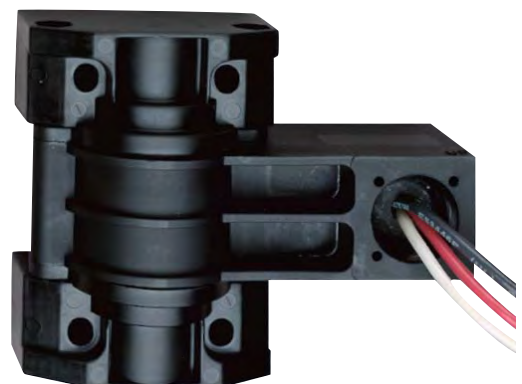

Moduflow™ Plus Series

Parts List

Flange Kits (flange, 4 bolts, o-ring)

Size	Code	Part Number	
		Buna	Fluorocarbon
¾ inch NPTF	YB	924788	926013
1 inch NPTF	YC	924787	926012
1¼ inch NPTF	YD	924912	926004
1½ inch NPTF	YE	924786	926011
2 inch NPTF	YF	924785	926010
SAE - 12	YM	924784	926009
SAE - 16	YN	924783	926008
SAE - 20	YO	924913	926005
SAE - 24	YP	924782	926007
BLANK FLANGE	—	924781	926006

RFP/ILP/ DILP Replacement Elements

Media	Nitrile Seals				Fluorocarbon Seals			
	New Single	Replaces Old Single	New Double	Replaces Old Double	New Single	Replaces Old Single	New Double	Replaces Old Double
02Q	937393Q	932686Q	937397Q	932692Q	937401Q	932689Q	937405Q	932695Q
05Q	937394Q	932687Q	937398Q	932693Q	937402Q	932690Q	937406Q	932696Q
10Q	937395Q	932688Q	937399Q	932694Q	937403Q	932691Q	937407Q	932697Q
20Q	937396Q	933116Q	937400Q	933117Q	937404Q	933118Q	937408Q	933119Q
WR	940733		940734		940735		940736	

Moduflow™ Plus Series

How to Order

BOX 1	BOX 2	BOX 3	BOX 4	BOX 5	BOX 6	BOX 7	BOX 8
ILP	1	10Q	B	MP	35	Y9Y9	1

BOX 1: Filter Series Symbol		Description
RFP		Return-line filter, inlet on side outlet on bottom
ILP		In-line filter
DILP		In-line duplex

BOX 2: Element Length Symbol		Description
1		Single
2		Double

BOX 3: Media Code Symbol		Description
02Q		Microglass III, 2 micron
05Q		Microglass III, 5 micron
10Q		Microglass III, 10 micron
20Q		Microglass III, 20 micron
WR		Water Removal

BOX 4: Seals Symbol		Description
B		Nitrile
E		EPR
V		Fluorocarbon

BOX 5: Indicator Symbol		Description
P		Pressure ports drilled & plugged only; no indicator
M		Visual indicator w/"no element" warning
E		Electrical indicator only
D		Electrical indicator only, 3-pin male receptacle

Note: First letter of indicator code = left side of filter head when looking into inlet with bowl down; second letter = right side of filter head when looking into inlet with bowl down.

BOX 6: Bypass Setting Symbol		Description
35		35 psid

BOX 7: Port Options				
Filter Model	Inlet Symbol/Description		Outlet Symbol/Description	
RFP	Y9	2" flange face	99	No fitting
	P9	SAE-24 integral threads	F9	2" NPTF
			F8	External check valve
ILP	Y9	2" flange face	Y9	2" flange face
	P9	SAE-24 integral threads	P9	SAE-24 integral threads
			E9	1½ NPTF integral threads
DILP	Y9	2" flange face	Y9	2" flange face

1) First pair of symbols denotes inlet for all filter styles; second pair of symbols denotes outlet.
 2) Four symbols required: two for inlet, two for outlet.
 3) Unused ports in filters come plugged with a blank flange.
 4) See Flange Kits table for port flange options. Flange Kits are ordered separately.

BOX 8: Options Symbol		Description
1		None

Moduflow™ Plus TFP Series

Bowl-less Design

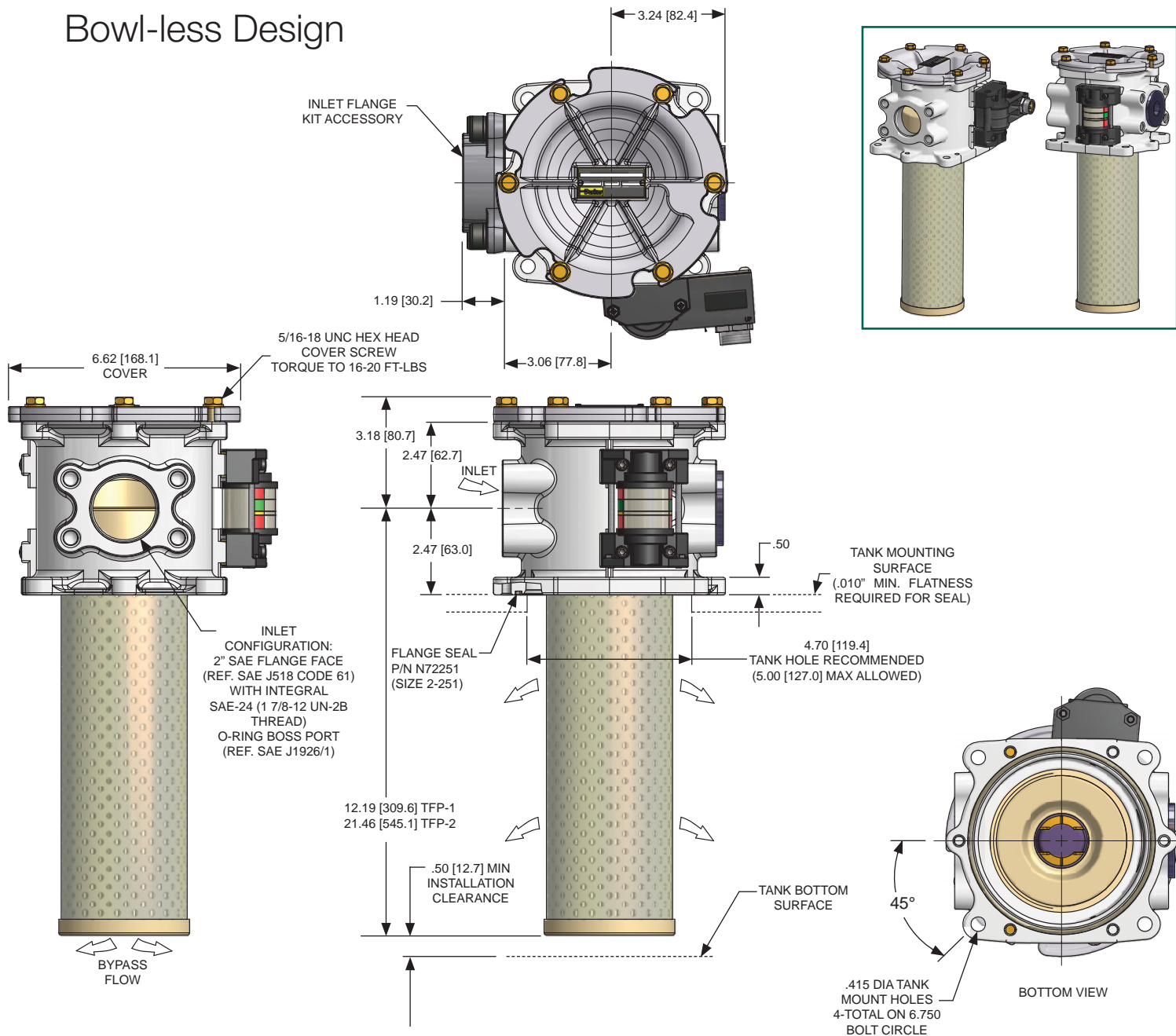

Features

- Shorter port-to-port distance.
- Direct tank mount capability eliminates need for adaptor flanges and bowl.
- Standard head incorporates 2" SAE flange face with integral SAE-24 port configuration.
- Filter head and element 2-piece construction requires no filter bowl.
- Patented element design with integral bypass valve and inside to out flow path.

Advantages

- Provides a smaller footprint and reduced weight.
- Aluminum die cast head reduces weight and direct tank mount flange reduces installation time and cost.
- Enables one common head to be used.
- Simplifies ordering model code.
- Reduces assembly cost by 25%.
- Ensures all contaminants remain captured during service.
- New bypass valve with each element ensures operation reliability.

Moduflow™ Plus TFP Series

How to Order

BOX 1	BOX 2	BOX 3	BOX 4	BOX 5	BOX 6	BOX 7	BOX 8
TFP	1	10Q	B	MP	35	C32	1

BOX 1: Series	
Symbol	Description
TFP	Return-line filter
TFPW	Return-line filter anodized for HWHC fluid

Box 2: Element Length	
Symbol	Description
1	Single
2	Double

Box 3: Media Code	
Symbol	Description
02Q	Microglass III, 2 micron
05Q	Microglass III, 5 micron
10Q	Microglass III, 10 micron
20Q	Microglass III, 20 micron
WR	Water Removal

BOX 4: Seals	
Symbol	Description
B	Nitrile
E	EPR
V	Fluorocarbon

BOX 5: Indicator	
Symbol	Description
P	Pressure ports drilled & plugged only; no indicator
M	Visual indicator w/"no element" warning
E	Electrical indicator only
D	Electrical indicator only, 3-pin male receptacle

Note: Two letters are required for the indicator code (e.g. "MP")

BOX 6: Bypass	
Symbol	Description
35	35 (2.4 bar) psid

BOX 8: Ports	
Symbol	Description
C32	2" SAE flange face/SAE-24 combination inlet port

BOX 8: Options	
Symbol	Description
1	None

Replacement Elements

Media	TFP-1			Media	TFP-2		
	Nitrile	Fluorocarbon	Ethylene Propylene		Nitrile	Fluorocarbon	Ethylene Propylene
02Q	937393Q	937401Q	937671Q	02Q	937397Q	937405Q	937675Q
05Q	937394Q	937402Q	937672Q	05Q	937398Q	937406Q	937676Q
10Q	937395Q	937403Q	937673Q	10Q	937399Q	937407Q	937677Q
20Q	937396Q	937404Q	937674Q	20Q	937400Q	937408Q	937678Q
WR	940733	940735	N/A	WR	940734	940736	N/A