

BGAH Series

Medium Pressure Filters

Max. 500 l/min. 25 bar



In-line solution for a straight pipeline

Pre-filtration by magnet column and a full-flow bypass with low hysteresis. Contamination-proof in-out filter principle. In- and outlet configuration allows integration in a straight pipeline. Nominal flow rate up to 500 l/min. Highly customizable for different applications.



Contact Information: Applications:

Parker Hannifin
Hydraulic Filter Division Europe

**European Product
Information Centre**
Freephone: 00800 27 27 5374
(from AT, BE, CH, CZ, DE, EE, ES,
FI, FR, IE, IT, PT, SE, SK, UK)
filtrationinfo@parker.com

www.parkerhfde.com

- Industrial gearboxes
- Wind turbines
- Stone crushers
- Bypass and off-line filtration
- Designed for hydraulic and lube applications

Specification

Assembly:

In-line filter

Maximum operating pressure:

25 bar

Nominal flow rate (30 cSt):

500 l/min (30 m³/h)

Connections:

Flanges SAE 3" 3000-M

Seal material:

Nitrile, optionally Fluoroelastomer or Neoprene

Operating temperature:

-40°C...+100°C with Nitrile seals, -20°C...+120°C with Fluoroelastomer seals. For other temperatures consult Parker Filtration.

Housing material:

Aluminium

Weight:

BGAH 3-400: 21 kg

BGAH 3-500: 28 kg

Bypass setting:

Opening pressure standard 1.5 bar, optionally 0.8 bar, 2.0 bar or blocked bypass

Filtration materials:

- Ecoglass for LEIF® element with reusable metal element sleeve. *LEIF*® contributes to ISO14001.
- Glassfibre Microglass III
- Resin impregnated cellulose paper 10µm nominal
- Cleanable metal mesh

Magnetic pack:

Standard

Differential pressure indicators:

Visual or Visual-electrical indicator

Setting 1.2 bar (for 2.0 bar and 1.5 bar bypass) or 0.7 bar (for 0.8 bar bypass)

Fluid compatibility:

Suitable for use with regular hydraulic and lubrication oils. For other fluids consult Parker Filtration.

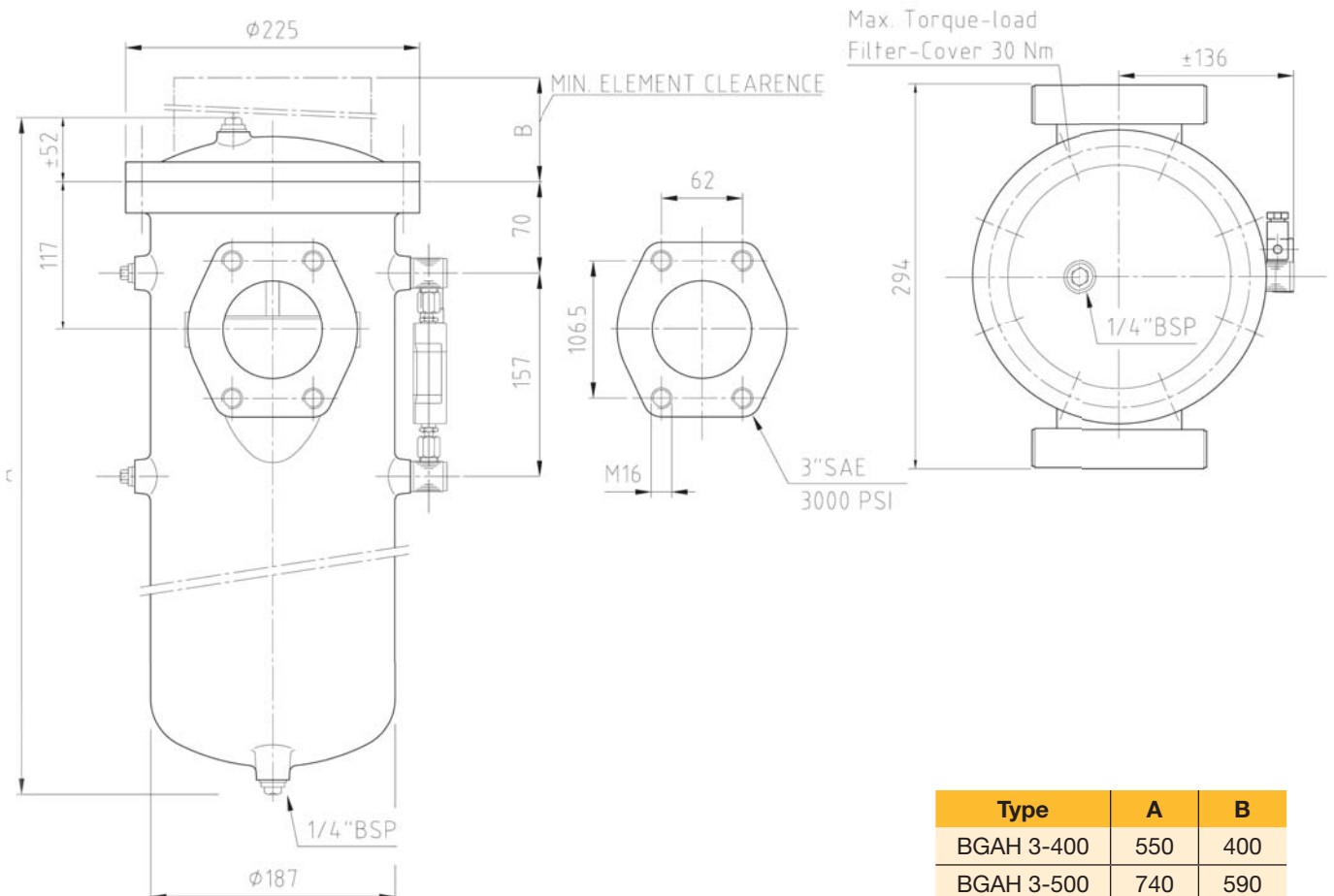

High differential pressure connection

VISUAL INDICATOR

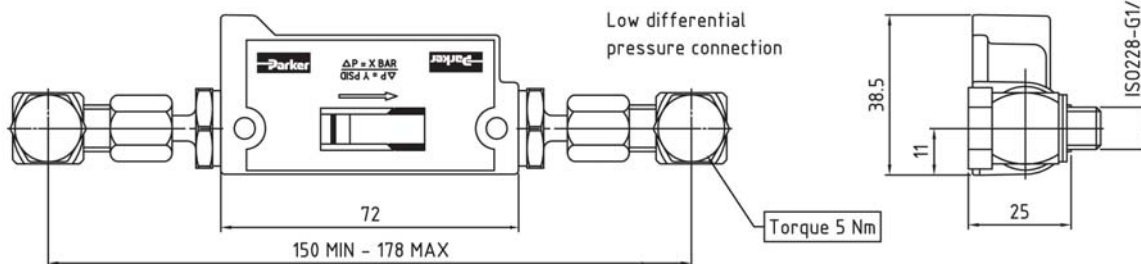

High differential pressure connection

VISUAL/ELECTRICAL INDICATOR

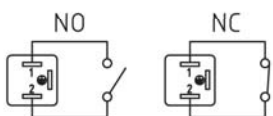
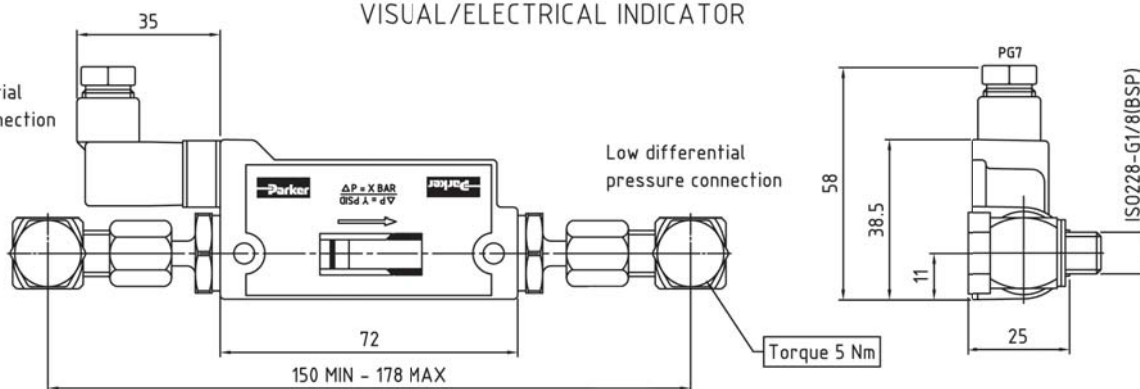

120V~/12VA } 0.5A
100V~/10W }

Visual Indicator - Mounted with couplings to filter housing

Code (0.7 bar setting)	FMUDABBAXXXL
Code (1.2 bar setting)	FMUDAEBAXXXL

Electrical Indicator - Mounted with couplings to filter housing

Code (0.7 bar setting and NO type switch)	FMUEBBBAXXXL
Code (1.2 bar setting and NO type switch)	FMUEBEBAXXXL
Electric rating	120Vac/12VA or 100Vdc/10W
Electrical connection	AMP terminal 6.3. x 0.8 with plugged cable gland
Protection	IP65
Switch type	NO (NC on request)

BGAH Series

Pressure Drop Curves

$$\Delta p_{\text{total}} = \Delta p_{\text{housing}} + \Delta p_{\text{element}}$$

The recommended level of the initial pressure drop for this filter is maximum 0.5 bar.

Δp -curves are measured at 30 cSt.

If the medium used has a viscosity different from 30 cSt, pressure drop over the element can be estimated as follows:

$$\Delta p_{\text{total}} = \Delta p_{\text{housing}} + \Delta p_{\text{element}} \times \frac{\text{working viscosity}}{30 \text{ cSt}}$$

BGAH housing

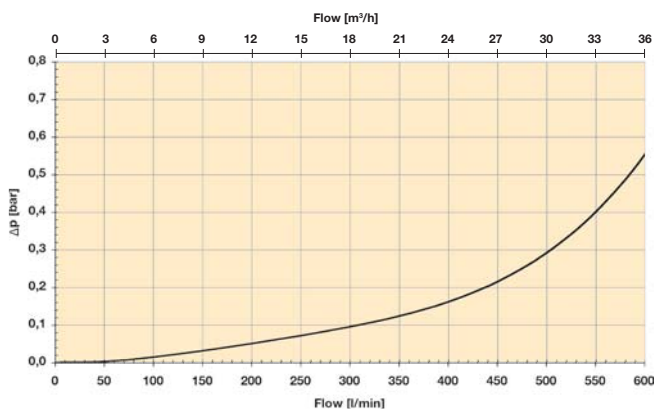

BGAH 3-400 elements (Length 11)

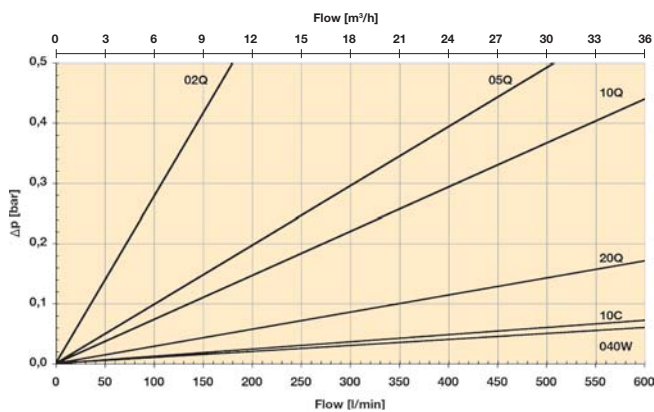

BGAH 3-500 elements (Length 12)

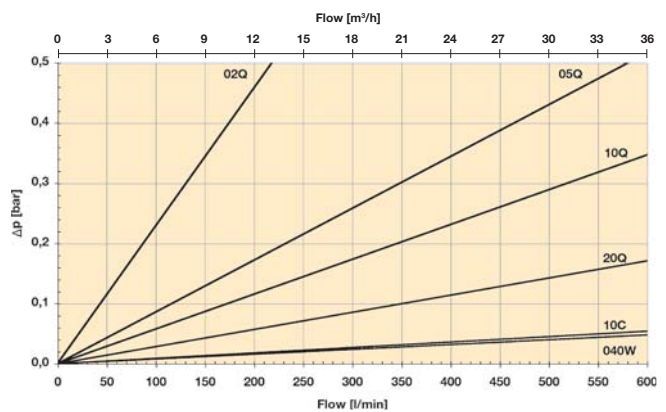

BGAH Series

Medium Pressure Filters

Product Description for BGAH

Complete Filter:

Table 1	Table 2	Table 3	Table 4	Table 5	Table 6	Table 7	Table 8

Table 1

FILTER TYPE	
Model	CODE
Medium pressure filter, aluminium	BGAH

Table 2

FILTER SIZE	
Housing size - element length	CODE
3-400	11
3-500	12

Table 3

DEGREE OF FILTRATION	
Element type	CODE
Microglass III	
Glassfibre 2 µm	02Q
Glassfibre 5 µm	05Q
Glassfibre 10 µm	10Q
Glassfibre 20 µm	20Q
LEIF® elements	
Glassfibre 2 µm	02QL
Glassfibre 5 µm	05QL
Glassfibre 10 µm	10QL
Glassfibre 20 µm	20QL
Other medias	
Cellulose 10 µm (nom)	10C
Cleanable metal mesh 40 µm	040W

Table 4

SEAL TYPE	
Seal material	CODE
Nitrile	B
Fluoroelastomer	V
Neoprene	N

Table 5

INDICATORS	
Options	CODE
Visual indicator on right*	D8
Visual indicator on left*	D9
Visual-electrical indicator on right*	E9
Visual-electrical indicator on left*	EA
Both indicator ports plugged	P2

* Indicator ports on other side machined and plugged.

Table 6

BYPASS VALVE	
Bypass/indicator setting	CODE
0.8 bar/0.7 bar	B
1.5 bar/1.2 bar	E
2.0 bar/1.2 bar	H
No/No	X

Table 7

FILTER CONNECTIONS	
Port size	CODE
SAE flange 3"-3000M	R48

Table 8

OPTIONS	
Options	CODE
With bypass and magnets	1
No bypass, with magnets	2
With bypass, no magnets	5
No bypass, no magnets	6

CONVENTIONAL TYPE REPLACEMENT ELEMENTS WITH NITRILE SEALS

Element length	Housing size	Microglass III				Cellulose 10 µm (nom)	Cleanable metal mesh 40 µm
		02Q	05Q	10Q	20Q		
11	3-400	937742Q	937763Q	937778Q	937799Q	937728	937813
12	3-500	937741Q	937764Q	937777Q	937800Q	937729	937812

LEIF® REPLACEMENT ELEMENTS

Element length	Housing size	Ecoglass III			
		02QL	05QL	10QL	20QL
11	3-400	937832Q	937843Q	937858Q	937869Q
12	3-500	937833Q	937842Q	937859Q	937868Q

SPARE PARTS

Seal kit	CODE
Seal material	
Nitrile	2049010000
Fluoroelastomer	2049010055
Neoprene	2049010034

Please note the bolded options reflect standard options with reduced lead-time.