



MANN+HUMMEL
ProVent² 500 Installation
and maintenance
instructions

1 Introduction

These installation and maintenance instructions are intended to familiarize you with the 2nd generation ProVent² 500 oil separator and its intended use. The installation and maintenance instructions contain important information on the safe, proper and economical operation of the components. Observing these instructions helps to avoid dangers and to increase the reliability and service life of your machine. The instructions must be made available to any person who is entrusted with work on the device. In principle, the existing national regulations for environmental protection (especially for the disposal of dismantled parts), the general accident prevention regulations and other generally recognized safety and occupational health regulations must be observed.

Non-compliance with the installation and maintenance instructions and the safety instructions contained therein can endanger persons, the filter system and the environment.

It is also essential to observe the safety instructions on the respective MANN+HUMMEL filter system or in its respective documentation!

Note for the operator:

According to the Work Equipment Usage Ordinance, the operator is responsible for providing work equipment that meets the basic safety and health requirements. This also includes using these work equipment in such a way that it is only used within the scope of its intended use. In addition to the maintenance intervals specified in the installation and maintenance instructions, the operator can also define his own inspection plans and intervals.

2 Manufacturer and publisher

MANN+HUMMEL GmbH

Industrial Filtration

Brunckstraße 15

67346 Speyer, Germany

Phone: +49 (62 32) 53-80

Fax: +49 (62 32) 53-88 99

Internet: www.mann-hummel.com

E-Mail: if.info@mann-hummel.com

3 Disclaimer

These safety instructions should not be regarded as a substitute for, but as a supplement to, the documentation of the respective MANN+HUMMEL filter system. The manufacturer has compiled them to the best of his knowledge. You cannot hold the manufacturer responsible for the function of the product in its final application over which he has no influence. You must observe these safety instructions and the documentation enclosed with the filter system and convince yourself of the safe usability of the product in its application by means of your own tests and release. Therefore, the manufacturer cannot be held liable for machine failures, damage or personal injury related to product failure in the application.

4 Means of presentation



DANGER!

A safety note with the signal word **DANGER!** warns of personal hazards that could possibly lead to serious or fatal injuries.



WARNING!

A safety note with the signal word **WARNING!** warns of personal hazards which could possibly lead to moderate injuries.



ATTENTION!

A safety note with the signal word **ATTENTION!** warns of material damage and personal hazards that can lead to minor injuries.

5 Basic safety instructions



DANGER!

- Contact with dangerous substances can lead to poisoning and burns. The safety instructions in the corresponding EC Safety Data Sheet (MSDS) must be observed!
- The filter system may be under pressure. Vent it by slowly opening a vent screw on the filter system or at another suitable point in the application.
- In this case, wear adequate protective clothing (safety glasses, face protection).
- Inflamed filter materials (e.g. fuel, oil) can cause serious burns.
- **Keep these filter materials away from heat, sparks, open flames and hot surfaces!**



WARNING!

- The operator of the machine or system is responsible for providing working and protective equipment which complies with the basic national safety and accident prevention regulations! This also includes using these working and protective equipment only within the scope of its intended use.
- Always ensure sufficient personal protective equipment (PPE) such as safety glasses, gloves and body protection.
- Ensure that only trained specialists such as car mechanics or persons who have undergone related training carry out the installation and maintenance of the MANN+HUMMEL filter system in accordance with the manufacturer's instructions. Make sure that the specialist has obtained sufficient information on installation and maintenance from the relevant installation and maintenance instructions.
- Keep the respective installation and maintenance instructions for the filter system and these safety instructions available at the installation site during the entire installation.
- Read the respective installation and maintenance instructions for the filter system as well as these safety instructions completely before installation and maintenance.
- Keep all inscriptions and markings on the filter system in a legible condition.
- If the filter system is supplied with a voltage for operation (e.g. for a diesel heater or fuel pump), disconnect the battery of the application before installation, dismantling and maintenance.



ATTENTION!

- Before installation, check the scope of delivery of the filter system for completeness and possible damage. If damaged parts are included in the delivery, please inform your sales partner.
- When installing the filter system, make sure that the screws provided for the respective position are securely fastened (length and torque).
- The dimensions of the screws, threaded bolts, washers and nuts as well as the tightening torque can be found in the respective quotation drawing.
- The inlet and outlet lines used must be approved for the filter medium used (e.g. oil or fuel). Unsuitable pipe materials can lead to leaks in the filter system.
- Make sure that no existing installations are damaged by the installation of the filter system.
- When connecting the inlet and outlet nozzles, make sure that the nozzles are not deformed by too tightly tightened fastenings (e.g. hose clamps).
- When installing the filter system, reattach the cable and hose clips that you removed when removing the filter system to the same place.
- After installation and maintenance, secure cables and hoses against unintentional movement.
- The connecting cables of the application must be able to be connected to the filter system without kinks or abrasion.
- Immediately eliminate any faults that may impair safety during operation of the filter system.
- If there is visible damage to the filter system and its components, they must not be obstructed and put into operation. Damage to the housing can impair the function of the filter system.
- Report any changes (including operating behavior) that affect the functional safety to the manufacturer or seller immediately.
- Install the filter system so that vibration, temperature and humidity (e.g. splash water or rain) cannot damage the application or the components of the filter system.
- When working on the application, the filter system must not be misused as a climbing aid.
- Do not use the filter system in humid environments if the housing design of the filter system is not waterproof. Follow the instructions on the filter system or in the respective documentation.
- If the filter system has a plastic housing, there is a risk of electrostatic discharge. Ensure a conductive connection to the installation site when installing the filter system.
- When installing and changing the filter system, make sure that no impurities (air, oil, fuel) enter the filter system or the application on the clean substance side.
- Do not operate the application without the filter system connected if this could damage the application.
- Always operate a powered filter system only with the permissible on-board voltage. Pay attention to the corresponding instructions on the filter system or in the respective documentation.
- Only use service components approved by the manufacturer. Filter system components that are not approved service components must not be replaced!
- Operation with inadmissible components is not intended use!
- Only use original MANN+HUMMEL replacement components.
- Store replacement filters away from dust, moisture, damage and inaccessible to insects and rodents.
- Dispose of the individual components of the filter system in accordance with official environmental regulations.
- Ensure that escaping filter media such as oil or fuel do not escape into the environment! Collect substances that are harmful to the environment (e.g. via a collecting tray) and dispose of these substances in accordance with official environmental regulations!

6 Intended use

- Only use the filter system in a technically perfect condition and in accordance with its intended purpose and in a safety-conscious and risk-conscious manner, observing the relevant installation and maintenance instructions, the quotation drawing and these safety instructions.
- Only operate it in compliance with these safety instructions and the respective assembly and maintenance instructions and with the intervals and conditions for inspections and maintenance work.
- The MANN+HUMMEL filter system is exclusively intended for mechanical oil separation of blow-by-gas or for crankcase ventilation of diesel engines. Any other use above or beyond this is considered unintended use. The manufacturer / supplier is not considered liable for damage resulting from unintended use.
- Only trained and authorized personnel are authorized to service the filter system. The operator is obliged to check the filter system once a week for externally recognizable damage and defects and to immediately report any changes that have occurred (including the operating behavior) which impair the functional safety.
- All inscriptions and markings on the filter system must be kept in a legible condition.
- Only use original MANN+HUMMEL spare parts.
- It is designed for continuous operation.

7 Unapproved use

- Do not use the filter system other than as described in the respective installation and maintenance manual or quotation drawing.
- Any other or more extensive use (e.g. filtration of aggressive, flammable or explosive media) is considered improper.
- Do not use it if you cannot comply with the operating conditions.
- You may not alter or modify it without the consent of MANN+HUMMEL.
- Operation with inadmissible components is not intended use!
- Do not operate the filter system if you have not carried out the necessary maintenance and repair work.

8 Functional description

ProVent² 500 is a crankcase ventilation system with integrated oil separation and pressure control that reduces vehicle emissions and minimizes deposits in the intake tract. The ProVent² 500 system separates the oily blow-by gases produced during fuel combustion with a separator and reduces the residual oil content to a minimum level.

The filter system essentially consists of an oil separator element and a pressure regulator. The ProVent² 500 can be used as an open system (oil separation only) or a closed system (with recirculation of the separated oil and the residual gas, as well as control of the crankcase pressure). When the crankcase ventilation is open, the pressure control is not effective. After flowing through the oil separator, the blow-by gas is led outside via the outlet nozzle. During operation, an overpressure is created in the crankcase.

In the closed system, the separated engine oil is returned to the oil pan and is thus available to the oil circuit again.

The formation of blow-by gases

Combustion gases (so-called blow-by gases between piston rings and bushings) enter the crankcase at each working stroke of an engine. This would result in an unacceptably high pressure in the crankcase after a few seconds. This is prevented by opening the crankcase at a suitable point.

The blow-by gases, which mix with oil mist from the engine, escape from this vent hole. ProVent² 500 can be used as an oil separation system to prevent the blow-by gases from transporting the oil out of the engine after prolonged operation and to prevent the environment from being polluted by oily blow-by gases. In turbocharged engines, air can also enter the crankcase via the turbocharger's oil return system.

ProVent² 500 systems are designed for both original equipment and retrofit. The following illustrations show possible superstructures and a cross-section of the system.

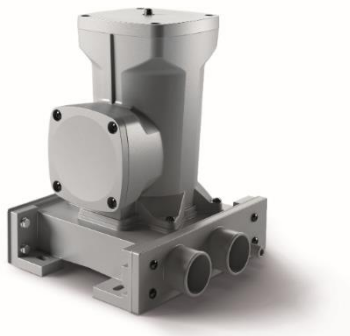

Figure. 1: Single system incl. Base module



Figure. 2: Modular design incl. Base module

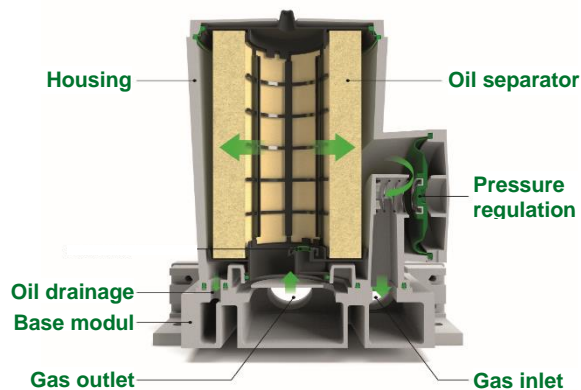

Figure. 3: cross section ProVent² 500 complete module

9 Installation and maintenance

Requirements for the installation site

ProVent² 500 can be mounted on the engine or frame of the machine / vehicle.

Inlet connection to the engine

The blow-by gases reach the ProVent² 500 via the inlet nozzle. Possible extraction points for the blow-by gas must be in an area with a low oil content. These are areas in which there are no moving parts and no splash oil is present, e.g. upper areas of the crankcase or the cylinder head cover.

This crankcase outlet must be connected to the ProVent² 500 system inlet port.

Connection principles Oil return

Connection below oil level

The oil return is connected to the engine via a drainage pipe below the minimum permissible oil level of the oil pan. When the engine is switched off (no blow-by gas), the same oil level is present in the oil pan and the drainage pipe.

When the engine is running, this oil trap acts like a siphon so that the blow-by is led over the oil separator when the oil is sucked out of the outlet nozzle. The differential pressure of the oil separator determines the height of the oil column in the oil return line. If an oil separator element is installed in the system, the same negative pressure is present in the oil return line during operation as at the oil separator. These relationships must be taken into account when selecting the installation location.

Connection above oil level

This connection variant requires an optionally available non-return valve. The valve is installed in the drainage pipe as close as possible to the oil level (approx. 30 to 50 mm above maximum oil level).

During operation, the separated oil accumulates above the non-return valve. During operation, the check valve is closed by the differential pressure of the separator. If the weight of the oil column exceeds the closing pressure of the valve, or after switching off the engine, the separated engine oil flows back into the oil pan.

Any inclined positions that may occur in mobile applications that lead to a fluctuating oil level must always be taken into account. MANN+HUMMEL generally recommends the use of a check valve for all ProVent installations.

Outlet within closed systems

The outlet nozzle is connected to the engine intake (after the air filter, but before the turbocharger, if fitted). The highest possible point above the oil level or non-return valve must be selected as the installation location, but at least 350 mm for the standard separator element.

The suction vacuum present during operation of a closed system sucks the blow-by via the respective ProVent² 500 and returns the cleaned blow-by gas to the intake tract of the engine. When selecting the installation location, the type of oil return must be taken into account.

Outlet within open systems

The outlet nozzle remains open. The cleaned blow-by gas is discharged into the open air.

Maintenance ProVent² 500

The element replacement or service of the element **LC 14 002** as shown below must be carried out according to the manufacturer's specified service intervals or according to requirements.

No other repair of the ProVent² 500 system by the driver or workshop personnel is planned.

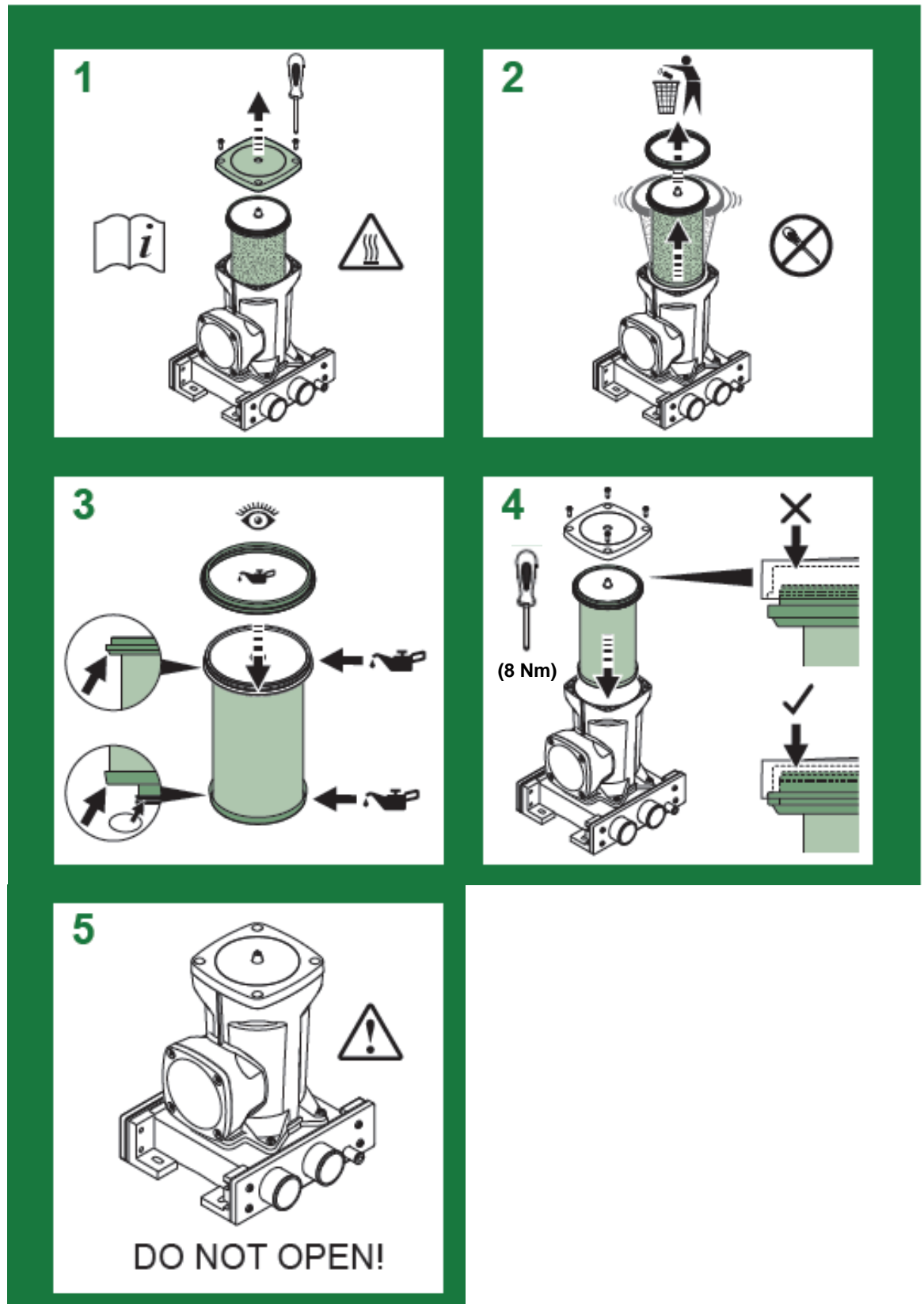

10 Other applicable documents

In addition to these installation and maintenance instructions, the following documents must also be observed and applied:

- Safety instructions on the respective MANN+HUMMEL filter system or in its documentation,
- EC safety data sheets of the corresponding filter material,
- Technical data of the filter system according to the quotation drawing,
- Operating and maintenance instructions of the application manufacturer,
- National safety and accident prevention regulations in the country of use governing the safe operation of the filter system,
- National laws and official regulations in the user country governing the operation of the filter system or the disposal of the filter system components.

