



## Cowl-Mounted Air Cleaner Superior Protection with RadialSeal™ Sealing Technology

Looking for a replacement to our older EBA cylindrical-shaped axial seal style air cleaner? Our ERA RadialSeal™ air cleaner series delivers a reliable filtration system for your engine and simplifies filter service.

*Our older, classic EBA cowl-mounted air cleaner (shown on the right) has been replaced with our ERA Air Cleaner.*

*EBA replacement filters are still available through your local Donaldson outlet.*



### Applications

- Light dust, single-stage air cleaner
- Vertical installation, mounted on the side of the truck
- Primarily for on-highway trucks
- Can be installed on driver or passenger's side
- Allows up to 1350 cfm airflow throughput per air cleaner

(Mounting the unit directly to the engine is not recommended)

### Air Cleaner Features

- Black, corrosion and chemical resistant polymer paint retains its finish through all types of weather
- Available in 11" (279mm), 13" (330mm) and 15" (381mm) diameter sizes
- Order inlet hoods separately
- Double airflow throughput by using two air cleaners
- Vacuator™ Valve automatically expels moisture from bottom of housing

*The ERA Style air cleaner has RadialSeal sealing technology and fewer access bolts to remove during service compared to our old EBA air cleaner design.*

*The exterior finish is glossy black, polymer paint.*

*Don't forget to protect the air cleaner from rain and exposure, by adding an inlet hood to the intake flange on the service cover. Pre-cleaner inlet hoods are featured in the accessories section.*



### Filter Features

- RadialSeal sealing technology — high tech resilient urethane ends that hold the filter firmly in place and maintain a tight, reliable seal — reduces the number of components and ensures reliability
- High efficiency, extended service, Donaldson Blue™ filters are available on some models (see service parts list on page 60 for part numbers)



**FLOW**

**Air in the End, Out the Side** (reverse flow filters)

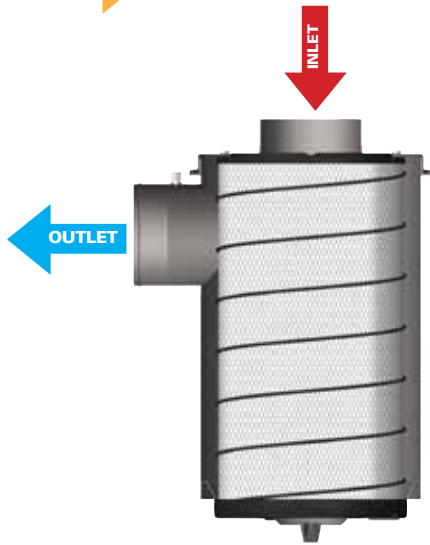

### When Selecting an Air Cleaner . . .

Determine the airflow requirements of your engine, then find the corresponding cfm airflow in the table at right. The restriction numbers (shown in inches of water) indicate the approximate initial restriction of each model air cleaner at that cfm. If there are two air cleaner models that fit your parameters, choosing the one with the lower restriction will provide longer filter service life. When calculating total initial restriction of the entire air intake system, include the restriction caused by ducting, elbows, and pre-cleaners.

### Initial Airflow Restriction

CFM @ "H <sub>2</sub> O			Air Cleaner Model
6"	8"	10"	
<b>ERA AIR CLEANER</b>			
750	870	970	A110052
760	880	890	A130115
760	880	980	A150141
1045	1205	1350	A150138

### ERA Specification Illustrations

Side and Top View

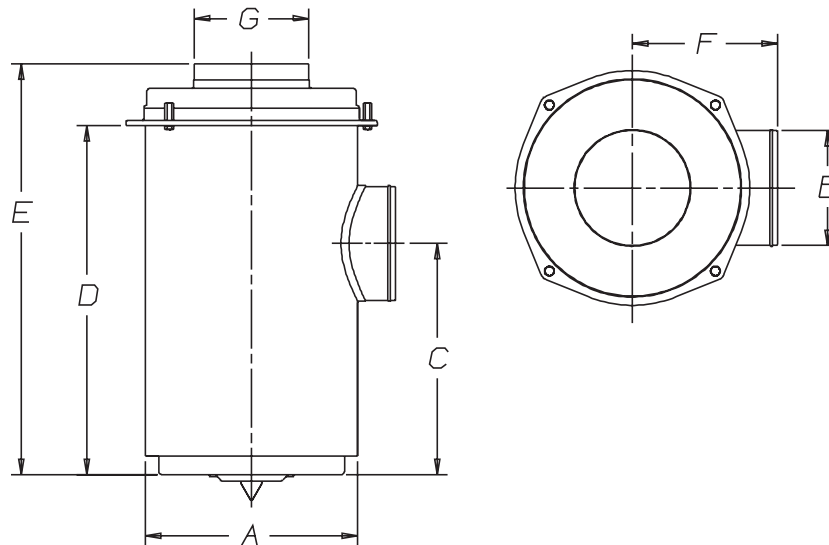

### ERA Specifications

Air Cleaner Models	Body Diameter (A)		Outlet Diameter (B)		Outlet Location (C)		Body Length (D)		Overall Length (E)		Outlet Location (F)		Inlet Dia. OD (G)		Service Clearance		Service Indicator Tap	Weight	
	in	mm	in	mm	in	mm	in	mm	in	mm	in	mm	in	mm	in	mm		lbs	kg
A110052	11.00	279	5.50	140	17.07	434	20.39	518	23.70	602	9.36	238	6.00	152	20.00	508	Yes	24	11
A130115	13.00	330	6.00	152	16.69	424	20.19	513	22.95	265	10.42	265	6.00	152	20.00	508	Yes	29	13
A150141	15.00	381	6.00	152	16.90	429	20.38	518	23.14	588	11.90	302	6.00	152	20.00	508	Yes	32	15
A150138	15.00	381	7.00	178	19.25	489	24.38	619	27.69	703	11.90	302	7.00	178	24.00	610	Yes	36	16



**ERA Service Parts & Accessories**

**A110052 ERA**

Bolt .....	P119463
Cover .....	P544744
Elbow, 45° .....	P105546
Elbow, 90° .....	P105534
Elbow, 90° reducing .....	P128990
Filter, primary-Donaldson Blue™ ...	DBA5148
Filter, primary - SM .....	P544741 .....3
Gasket, cover .....	P155211
Hump hose .....	P105611
Informer™ indicator 25" H <sub>2</sub> O .....	X002277
Inlet hood, metal .....	H000275
Inlet hood, plastic .....	H000606
Mounting band, black, metal .....	P004079
Nut, plastic .....	P119325
Outlet band clamp .....	P148346
Retaining ring .....	P129469
Vacuator™ Valve .....	P149099

**A130115 ERA**

Bolt .....	P119463
Cover .....	P542475
Filter, primary - SM .....	P544950 .....3
Filter, primary-Donaldson Blue™ ...	DBA5149
Gasket, cover .....	P155264
Mounting band, black .....	P013722
Nut, plastic .....	P119325
Retaining ring .....	P129469
Vacuator™ Valve .....	P149099

**A150141 ERA**

Bolt .....	P119463
Cover .....	P544827
Elbow, 45° .....	P105547
Elbow, 90° .....	P105535
Filter, primary-Donaldson Blue™ ...	DBA5151
Filter, primary - SM .....	P544243 .....3
Gasket, cover .....	P535559
Hump hose .....	P105612
Informer™ indicator 25" H <sub>2</sub> O .....	X002277
Inlet hood, metal .....	H000275
Inlet hood, plastic .....	H000606
Mounting band, metal, black .....	P016845
Nut, plastic .....	P119325
Outlet band clamp .....	P148347
Retaining ring .....	P129469
Vacuator™ Valve .....	P149099

**A150138 ERA**

Bolt .....	P119463
Cover .....	P544238
Elbow, 45° .....	P105548
Elbow, 90° .....	P105536
Filter, primary-Donaldson Blue™ ...	DBA5150
Filter, primary - SM .....	P544301 .....3
Gasket, cover .....	P535559
Hump hose .....	P105613
Informer™ indicator 25" H <sub>2</sub> O .....	X002277
Inlet hood, metal .....	H000339
Inlet hood, plastic .....	H000607
Mounting band, black, metal .....	P016845
Nut, plastic .....	P119325
Outlet band clamp .....	P148348
Retaining ring .....	P129469
Vacuator™ Valve .....	P149099

Requires Inlet Hood — See Accessories section for choices and order separately.

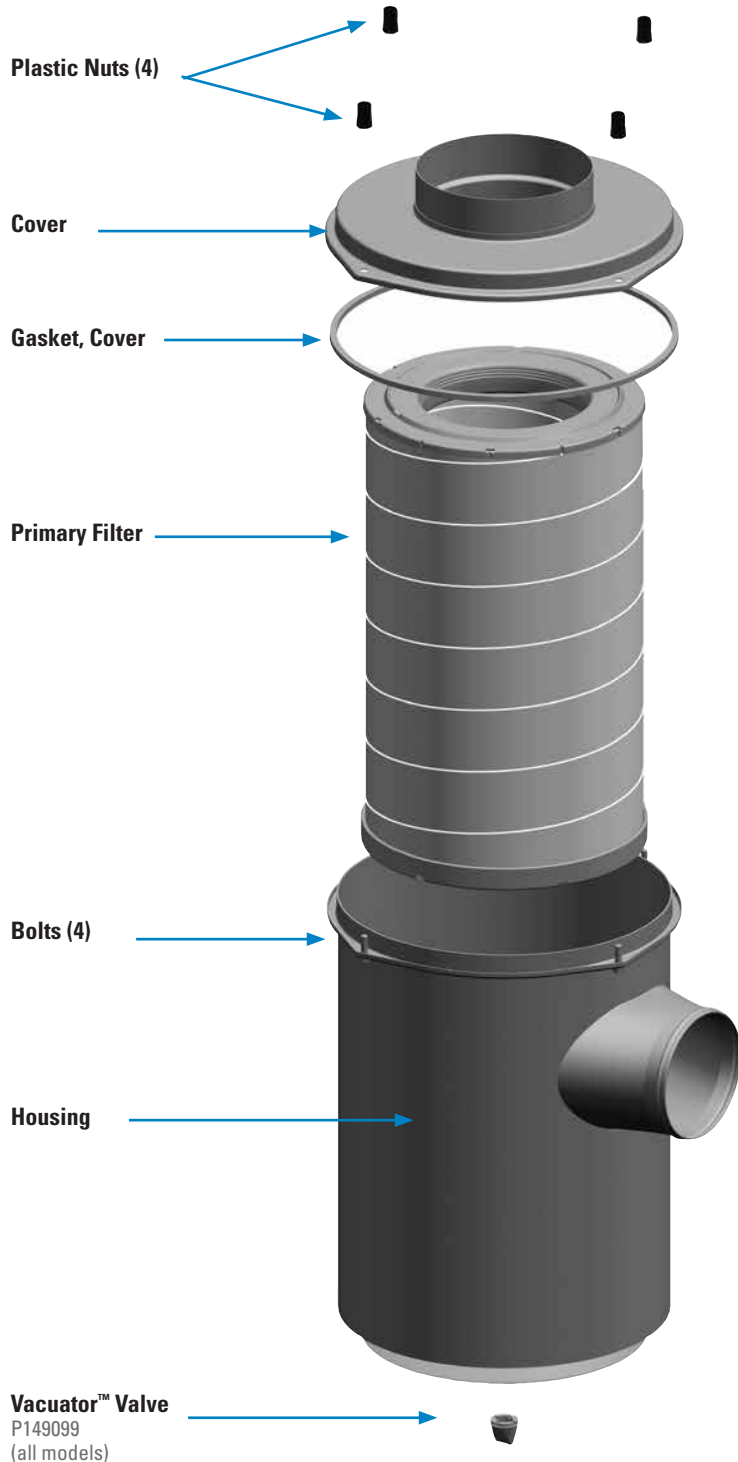

**NOTES:**  
3 = Shipped with air cleaner initially

SM = Scheduled Maintenance  
Donaldson Blue™ = High Efficiency, Extended Service

This servicing information is provided as a best practices guide. It is not intended to replace or supersede the service instructions supplied by your engine or vehicle manufacturer.

## 1 Check the Restriction

Replace the filter only when the restriction level has reached the maximum recommended by the engine or equipment manufacturer or on a regular service schedule. Restriction indicators, mounted on the air cleaner system are recommended for keeping an eye on restriction levels and indicating when servicing is due.



## 2 Remove the Filter

Unfasten or unlatch the service cover.

Because the filter fits tightly over the outlet tube to create the critical seal, there will be some initial resistance, similar to breaking the seal on a jar. Gently move the end of the filter back and forth to break the seal. Rotate while pulling the filter straight out. Avoid knocking the filter against the housing.



## 3 Check the Vacuator™ Valve

If your air cleaner is equipped with a Vacuator Valve, visually check and physically squeeze it. Make sure the valve is flexible and not inverted, damaged or plugged.



## 4 Inspect the Old Filter

Inspect the old filter for any signs of leaks. A streak of dust on the clean side of the filter is a telltale sign. Eliminate any source of air leaks before installing the new primary filter.



## 5 Clean Both Surfaces of the Outlet Tube

Use a clean damp cloth to wipe the filter sealing surface and the inside of the outlet tube. Contaminant on the sealing surface could hinder an effective seal and cause leakage.



*Continued on next page*



### 6

#### Inspect the New Filter

Visually inspect the new filter, paying special attention to the sealing area which is inside the open end. As you inspect the filter's RadialSeal™ take care not to wipe the sealing surface. The factory has placed a dry lubricant on the seal which aids in installation and removal.

NEVER install a damaged filter.



### 7

#### Insert the New Filter

Seat the filter by hand, making certain it is completely inserted into the air cleaner housing before securing the cover in place. To complete a tight seal, apply pressure by hand at the outer rim of the filter, not the flexible center. Never use the service cover to push the filter into place since no cover pressure is required to hold the seal.

Note that a cover gasket is usually supplied with ERA replacement filters. It is important that it be fitted at the same time as the new filter to ensure that the housing is airtight.

Using the cover to apply pressure could damage the housing and cover fasteners, and will void the warranty. If the new filter is not fully in place, remove the cover and push the filter further into the air cleaner with hand pressure on the outer rim. The cover should then go on with no extra force. Then, secure the service cover.



### 8

#### Check Connectors for a Tight Fit

Make sure restriction indicators are reset and in proper working order. Verify that all mounting bands, clamps, bolts, and connections in the entire air cleaner system are tight. Check for holes in piping and repair or replace as needed. Any leaks in the intake piping will admit dust directly to the engine.

