

## Many sizes Designed to Fit all Donaldson Air Cleaners

- Durable, corrosion resistant, steel construction.
- Fully engineered and tested to resist the adverse effects of vibration.
- Mounting band feet are designed to ensure maximum torque pressure, continuously.
- Gauge of steel increases as diameter of mounting band increases.
- Bright stainless models available.
- Bolt and nut included with mounting band.
- Used on all Axial Seal Air Cleaners and FRG Radial Seal Air Cleaners.

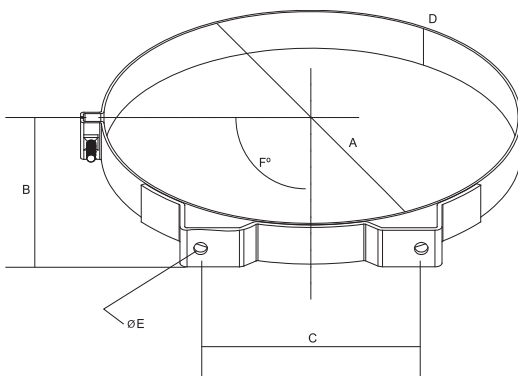

Most of our Air Cleaners with metal housings require two mounting bands.



Part Number	Dimensions (mm)					
	A	B	C	D	E	F
P004055	111	68	82,5	19	9,0	90
P002348	134	81	82	22	9,0	90
P002351	153	91	83	26	9,0	90
P007191	165	99	95	22	11 X 16	90
P004906	178	105	111	22	10 X 13	90
E500206	203	114	108	25	12 X 17	90
P004307	203	114	108	25	9	90
P004073	229	130	114	32	12	90
P004076	259	146	127	32	12	90
H770025*	259	146	127	32	12	90
P004079	279	156	127	32	11	90
H000349	300	175	152	38	11	90
P013722	330	184	152	38	10	90
H770065	330	206	203	38	12	90
H770059	345	191,5	142	38	10	90
H000350	356	206	203	38	12	90
P016845	381	203	203	38	12	90
H000351	407	231	254	38	12	90
H770037	457	234	400	50	14	105
H770068	546	279	490	48	14	105

\* With cage nut