

## Air in the Side, out the End (standard flow filters)

### When Selecting an Air Cleaner . . .

Determine the airflow requirements of your engine, then find the corresponding cfm airflow in the table below. The restriction numbers (shown in inches of water) indicate the approximate initial restriction of each model air cleaner at that cfm. If there are two air cleaner models that fit your parameters, choosing the one with the lower restriction will provide longer filter service life. When calculating total initial restriction of the entire air intake system, include the restriction caused by ducting, elbows, and pre-cleaners.



When servicing the EBB, make sure to replace the cover gasket when changing filters.

### Initial Airflow Restriction

CFM @ "H <sub>2</sub> O			Air Cleaner Model
6"	8"	10"	
620	730	800	B120271
900	1050	1320	B140044
1360	1530	1640	B160049

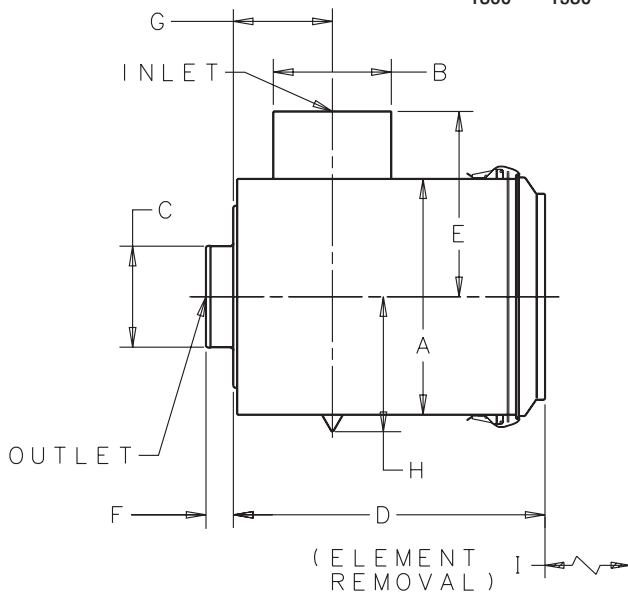

### EBB Specifications NOTE: All EBB Air Cleaners are tapped to accept a filter service indicator

Air Cleaner Models	Body Diameter (A)		Inlet Diameter (B)		Outlet Diameter (C)		Length (D)		(E)		Inlet Length (F)		(G)		(H)		Service Clearance (I)		Weight	
	in	mm	in	mm	in	mm	in	mm	in	mm	in	mm	in	mm	in	mm	in	mm	lbs	kg
B120271	11.81	300	5.50	140	5.00	127	16.42	417	7.64	194	2.00	51	5.80	147	--	--	16.0	406	16	7
B140044 <sup>1</sup>	14.00	356	7.00	178	6.00	152	18.50	470	10.90	277	1.62	41	5.88	149	8.00	203	17.5	445	19	8
B160049 <sup>2</sup>	16.00	406	8.00	203	7.00	178	18.75	476	12.91	328	2.50	64	8.84	225	--	--	18.0	457	35	16

1 - B140044 is only model with installed Vacuator™ Valve 2 - Access cover secured with bolts

**Service Parts & Accessories**

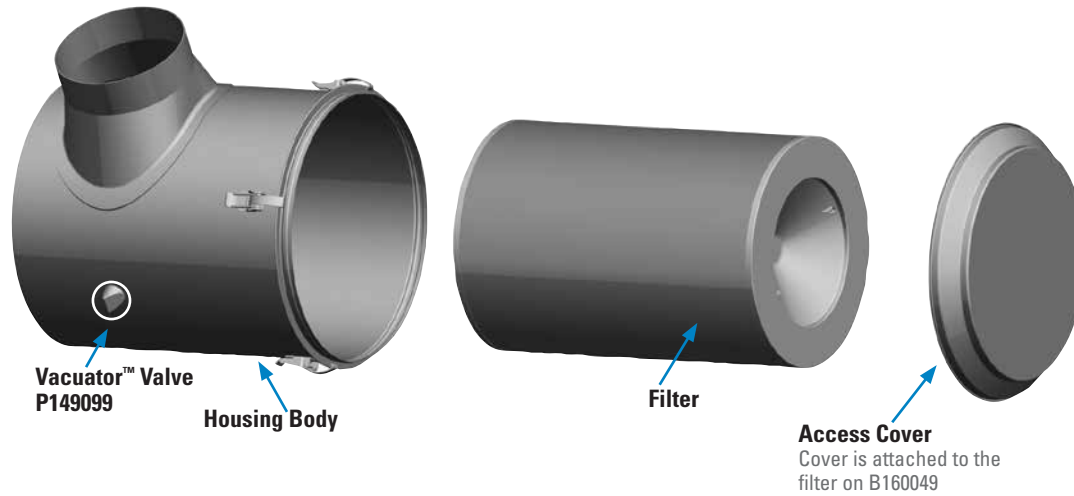

**B120271**

Elbow, 45° .....	P109021
Elbow, 90° .....	P107844
Elbow, 90° reducing .....	P143895
Filter, primary .....	P182028
Filter, primary - Donaldson Blue™ .....	DBA5028
Filter, primary - SM .....	P181028 ....3
Hump hose .....	P105610
Informer™ indicator 25" H <sub>2</sub> O .....	X002277
Inlet hood, plastic .....	H000604
Mounting band, metal .....	H000349 ....2
Outlet band clamp .....	P148345

**B140044 EBB**

Elbow, 45° .....	P105547
Elbow, 90° .....	P105535
Filter, primary .....	P182015
Filter, primary - Donaldson Blue™ .....	DBA5015
Filter, primary - SM .....	P181015 ....3
Hump hose .....	P105612
Informer™ indicator 25" H <sub>2</sub> O .....	X002277
Inlet hood, metal .....	H000339
Inlet hood, plastic .....	H000607
Mounting band, metal .....	H000350 ....2
Outlet band clamp .....	P148347

**B160049 EBB**

Elbow, 45° .....	P105548
Elbow, 90° .....	P105536
Filter, primary .....	P182099 ....3,6
Filter, primary - Donaldson Blue™ .....	DBA5099
Filter, primary - SM .....	P181099 ....6
Hump hose .....	P105613
Informer™ indicator 25" H <sub>2</sub> O .....	X002277
Inlet hood, plastic .....	H001053
Mounting band, metal .....	H000351 ....2
Outlet band clamp .....	P148348

**NOTES:**

- 2 = Two required for proper installation
- 3 = Shipped with air cleaner initially
- 6 = Access cover is attached to filter

SM=Scheduled Maintenance  
Donaldson Blue™ = High Efficiency, Extended Service



This servicing information is provided as a best practices guide. It is not intended to replace or supersede the service instructions supplied by your engine or vehicle manufacturer.

### 1 Check the Restriction

Check the restriction of the air cleaner with a Donaldson filter service indicator, service gauge, or a water manometer.

Replace the filter only when the restriction level has reached the maximum recommended by the engine or equipment manufacturer or on a regular service schedule.



### 2 Gently Remove the Old Filter

Switch the engine off. Handle the dirty filter gently, until it is clear of the air cleaner housing. Accidental bumping will shake dirt loose inside the filter housing.



### 3 Clean the Inside of the Housing

Always clean the inside of the housing. Dirt left in the air cleaner housing can potentially damage your engine.

Use a clean, damp cloth to wipe every surface clean. Ensure that the outlet tube sealing area is clean and undamaged.



### 4 Check the Inside Visually Before Installing the Filter

Always clean the gasket sealing surface. An improper gasket seal is one of the most common causes of engine contamination. Make sure that all hardened dirt ridges are completely removed, both on the bottom and top of the air cleaner housing.

Check for uneven dirt patterns. Your old filter has valuable clues to dust leakage or gasket sealing problems. A pattern on the filter's clean side is a sign that the old filter was not firmly sealed or that a dust leak exists. Identify the cause of that leak and rectify it before installing a new filter.



## 5 Inspect the New Filter Before Installation

Check the new filter but don't install it if it appears damaged. Check that the gasket is easily compressible and springs back promptly when finger pressure is released.



## 6 Install the New Filter

It is important to change the newly supplied cover gasket with each filter service. Ensure that the filter is the correct size for the housing and install the filter, making sure the gasket seats evenly for a perfect seal. Without a proper seal, dirty air can by-pass the filter.



## 7 Ensure Air-tight Fit on All Connections and Ducts

Check that all clamps, flange joints and air cleaner mounting bands are tight. Attend to any leaks immediately to avoid dirt entering your engine directly. If the vehicle is fitted with air brakes, it is important to check the clean air supply hose that feeds the air brake compressor.



### Reset the Indicator

If your system has a remote indicator, don't forget to reset it after filter service.

Total Filtration Solutions  
Vehicles • Engines • Equipment

